

DTSU666 Three phase electronic energy meter user manual

1. Overview of products

1.1 Applicable range

The DTSU666 meter mainly applied into the measurement and display for the photovoltaic system parameters in the electric circuit including voltage, current, power, frequency, power factor, active energy, etc. The network can be realized through RS485 communication interface and external device. Adopting the standard DIN35mm din rail mounting and modular design, it is characterized with small volume, easy installation and easy networking.



1.2 Specification for product model

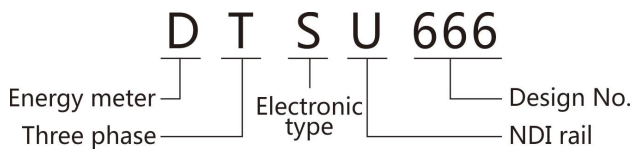

1.3 Outline & Mounting Dimension

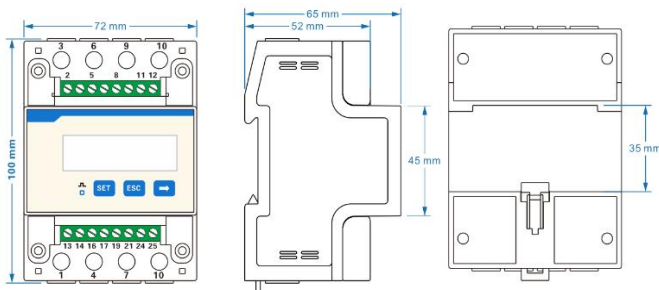

2. Datasheet

Type	DTSU666-H
Electrical Characteristics	
Application	Three phase
Nominal Voltage[V]	3×220/380
Operating range	0.7~1.2Un
Max. Current [A]	100A/40mA
Frequency/Range [Hz]	50,60±5
Power Consumption[W]	≤1
Max. Instant Consumption [VA]	≤5
Physical Parameters	
Display	LCD
Communication	RS485
Operating Temperature Range	-40°C~60°C
Ambient Humidity	0-95% Non-condensing
Ingress Protection	IP54
Installation method	mounting rack
Dimensions[H*W*D][mm]	98*72*65
Weight [kg]	0.4
Applicable Standard	CE, RoHS

3. Instructions for installation

3.1 Check the Package

Check whether the product shell in the carton is damaged, if is, please contact the supplier

3.2 Installation

Directly clip the instrument on the rail and install it on the distribution box.

(1)When installing, firstly clip one terminal of the slot and then clip to the rail with power. (standard DIN35mm)

(2)When disassembling, press the movable card with a screwdriver and take out the instrument.



Figure 3.1 Meter installation

3.3 Instruction of wiring terminal

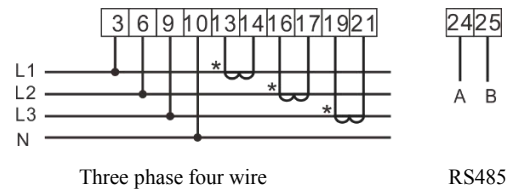

Figure 3.2 Direct connection

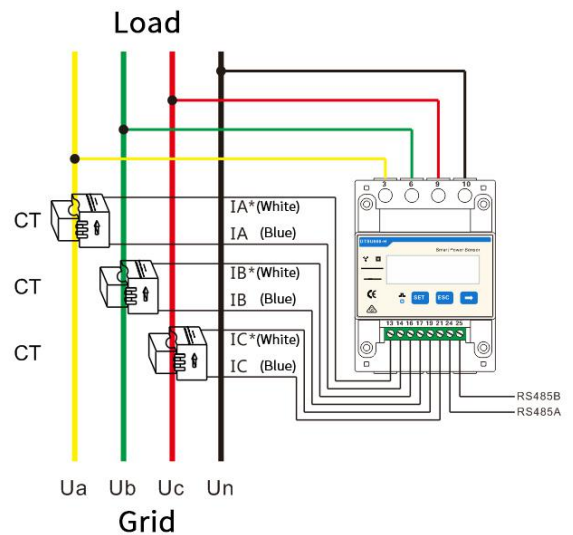

Figure 3.3 Meter connection diagram

3.4 RS485 interface of invert

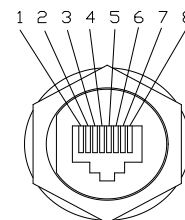

Figure 3.4 RS485 pin of R5series

PinNumber	Description	Effect
1	NC	
2	GND_W	Ground wire
3	+7V_W	Power supply
4	NC	
5	NC	
6	NC	
7	RS485-A	Transmission RS485 differential signal
8	RS485-B	

Table 3.1 RS485 pin port definition



Figure 3.4 RS485 connector of Suntrio Plus series

Number of connector	Description
1	B-
2	A+
3	Metal-shielded wire

Table 3.2 RS485 pin port definition

4. Fault and troubleshooting

Fault phenomenon	Reason analysis	Elimination
Display fault	1. Incorrect wiring 2. Abnormal voltage for the instrument	1. If it is wrongly connected, please reconnect based on the right wiring mode (see the wiring diagram). 2. If the supplied voltage is abnormal, please choose the specified voltage.
Communication fault	1. RS485 communication cable is opened, short circuit or reversely connected. 2. Address, baud rate, data bit and check bit is not in accordance with the host computer.	1. If there is any problem with the communication cable, please change it. 2. Set the address, baud rate, data bit and check bit through buttons and confirm it is the same with the host computer, then set the operation to be "parameter settings".
Abnormal data for the electrical parameter	Wrong wiring	If wrongly connected, please connect the voltage of phase A, B and C to the wiring terminal of the instrument

5. Meter setting

Button description: "SET" button represents "confirmation", or "cursor shift" (when input digits), "ESC" button represents "exit", "→" button represents "add". The input code is (default 701).

The factory default value of the baud rate is 9600, address is 1. There is no need to set, if you need to change as follows:

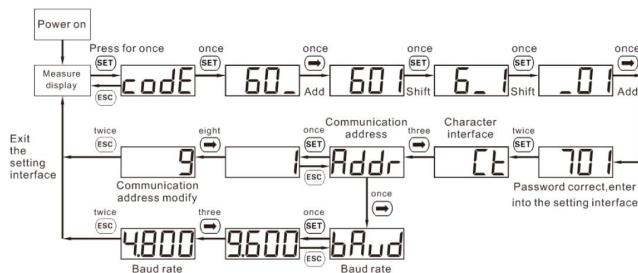

When input digits, "→" can be used as cursor "motion" button; "→" is "add" button, "ESC" is Exit the programming operation interface or switch to the character interface from digit modification interface, add from the beginning after setting the digit to the maximum value.

6. Export limitation function setting

6.1 The steps for matching R5 series

(1) Download eSolar O&M APP

Web to eSolar website <https://fop.saj-electric.com> to scan the QR code and download "eSolar O&M" APP (or download it from Google Play or App Store by searching "eSolar O&M"). After the installation on your phone, please login it with your installer account.

(2) Log in APP → Click "My" → Click "Remote control" → Click "WiFi" / "Bluetooth" → Click "Next step". as shown in Figure 6.1. Please refer to WiFi/GPRS/4G module manual for detailed connection operation.

(3) Enter "local connect" page and select "Export limitation setting" → input password : 201561 as shown in Figure 6.2.

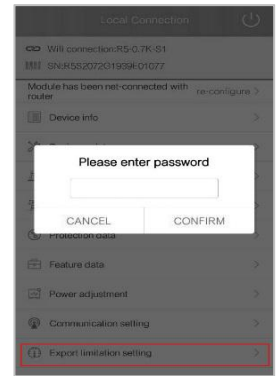

Figure 6.1 Local connect Figure 6.2 Export limitation setting

(4) Turn on "export limitation", Wait for 15s countdown seconds to set successfully, supply the power mode and current mode, as shown in Figure 6.3 and Figure 6.4

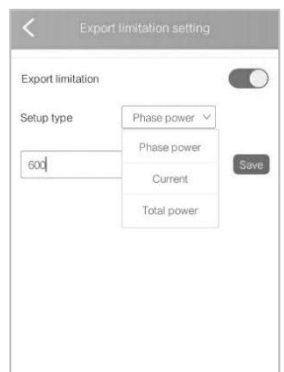
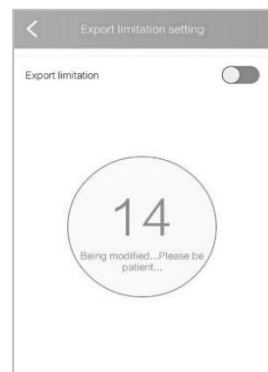

Figure 6.3 Countdown interface Figure 6.4 Power limit/Current limit setting

6.2 The steps for matching Suntrio Plus series

	LCD Display	Operation Steps																																																				
	Export Limitation Function																																																					
Export Limit	<table border="1"> <thead> <tr> <th>Graph</th> <th>Setting</th> <th>Run-Info</th> <th>About</th> </tr> </thead> <tbody> <tr> <td>▲</td> <td>Grid Compliance</td> <td></td> <td>Power 1230W</td> </tr> <tr> <td>10.8</td> <td>Clear Errors</td> <td></td> <td>E-Today 11.33 kWh</td> </tr> <tr> <td>9.6</td> <td>Clear Energy</td> <td></td> <td>E-Total 14.35 kWh</td> </tr> <tr> <td>8.4</td> <td>LCD Setting</td> <td></td> <td>T-today 1.7 h</td> </tr> <tr> <td>7.2</td> <td>Factory Reset</td> <td></td> <td>T-Total 4.6 h</td> </tr> <tr> <td>6.0</td> <td>Change Password</td> <td></td> <td></td> </tr> <tr> <td>4.8</td> <td>PV Mode Setting</td> <td></td> <td></td> </tr> <tr> <td>3.6</td> <td>Authorization</td> <td></td> <td></td> </tr> <tr> <td>2.4</td> <td>Export Limit</td> <td></td> <td></td> </tr> <tr> <td>1.2</td> <td></td> <td></td> <td></td> </tr> <tr> <td>0</td> <td></td> <td></td> <td></td> </tr> <tr> <td></td> <td>Normal</td> <td>E-Today 11.33 kWh</td> <td>19-07-20 15: 47</td> </tr> </tbody> </table>	Graph	Setting	Run-Info	About	▲	Grid Compliance		Power 1230W	10.8	Clear Errors		E-Today 11.33 kWh	9.6	Clear Energy		E-Total 14.35 kWh	8.4	LCD Setting		T-today 1.7 h	7.2	Factory Reset		T-Total 4.6 h	6.0	Change Password			4.8	PV Mode Setting			3.6	Authorization			2.4	Export Limit			1.2				0					Normal	E-Today 11.33 kWh	19-07-20 15: 47	<ol style="list-style-type: none"> In the main LCD interface, press "ENT" button, then press "▶" key to enter into "Setting". Press "▼" key to select export limitation, and then press "ENT" button to enter. Password: 201561
	Graph	Setting	Run-Info	About																																																		
	▲	Grid Compliance		Power 1230W																																																		
10.8	Clear Errors		E-Today 11.33 kWh																																																			
9.6	Clear Energy		E-Total 14.35 kWh																																																			
8.4	LCD Setting		T-today 1.7 h																																																			
7.2	Factory Reset		T-Total 4.6 h																																																			
6.0	Change Password																																																					
4.8	PV Mode Setting																																																					
3.6	Authorization																																																					
2.4	Export Limit																																																					
1.2																																																						
0																																																						
	Normal	E-Today 11.33 kWh	19-07-20 15: 47																																																			
Power Mode	<table border="1"> <thead> <tr> <th>Graph</th> <th>Setting</th> <th>Run-Info</th> <th>About</th> </tr> </thead> <tbody> <tr> <td></td> <td>Limit enable: <input checked="" type="checkbox"/> On <input type="checkbox"/> Off</td> <td></td> <td>Power 1230W</td> </tr> <tr> <td></td> <td>Limit mode: Power mode</td> <td></td> <td>E-Today 11.33 kWh</td> </tr> <tr> <td></td> <td>Limit power: 0 %</td> <td></td> <td>E-Total 14.35 kWh</td> </tr> <tr> <td></td> <td>Limit current: 0.0A</td> <td></td> <td>T-Today 1.7 h</td> </tr> <tr> <td></td> <td><input type="button" value="OK"/> <input type="button" value="Return"/></td> <td></td> <td>T-Total 4.6 h</td> </tr> <tr> <td></td> <td>Normal</td> <td>Export Limit</td> <td>19-07-20 15: 47</td> </tr> </tbody> </table>	Graph	Setting	Run-Info	About		Limit enable: <input checked="" type="checkbox"/> On <input type="checkbox"/> Off		Power 1230W		Limit mode: Power mode		E-Today 11.33 kWh		Limit power: 0 %		E-Total 14.35 kWh		Limit current: 0.0A		T-Today 1.7 h		<input type="button" value="OK"/> <input type="button" value="Return"/>		T-Total 4.6 h		Normal	Export Limit	19-07-20 15: 47	<ol style="list-style-type: none"> Turn on the "Limit enable". Select the "Power mode". Please set the percentage limited by the export limitation power according to practical situation. Click "OK" when completing the setting. 																								
	Graph	Setting	Run-Info	About																																																		
	Limit enable: <input checked="" type="checkbox"/> On <input type="checkbox"/> Off		Power 1230W																																																			
	Limit mode: Power mode		E-Today 11.33 kWh																																																			
	Limit power: 0 %		E-Total 14.35 kWh																																																			
	Limit current: 0.0A		T-Today 1.7 h																																																			
	<input type="button" value="OK"/> <input type="button" value="Return"/>		T-Total 4.6 h																																																			
	Normal	Export Limit	19-07-20 15: 47																																																			
Current Mode	<table border="1"> <thead> <tr> <th>Graph</th> <th>Setting</th> <th>Run-Info</th> <th>About</th> </tr> </thead> <tbody> <tr> <td></td> <td>Limit enable: <input checked="" type="checkbox"/> On <input type="checkbox"/> Off</td> <td></td> <td>Power 1230W</td> </tr> <tr> <td></td> <td>Limit mode: Current mode</td> <td></td> <td>E-Today 11.33 kWh</td> </tr> <tr> <td></td> <td>Limit power: 0 %</td> <td></td> <td>E-Total 14.35 kWh</td> </tr> <tr> <td></td> <td>Limit current: 0.0A</td> <td></td> <td>T-Today 1.7 h</td> </tr> <tr> <td></td> <td><input type="button" value="OK"/> <input type="button" value="Return"/></td> <td></td> <td>T-Total 4.6 h</td> </tr> <tr> <td></td> <td>Normal</td> <td>Export Limit</td> <td>19-07-20 15: 47</td> </tr> </tbody> </table>	Graph	Setting	Run-Info	About		Limit enable: <input checked="" type="checkbox"/> On <input type="checkbox"/> Off		Power 1230W		Limit mode: Current mode		E-Today 11.33 kWh		Limit power: 0 %		E-Total 14.35 kWh		Limit current: 0.0A		T-Today 1.7 h		<input type="button" value="OK"/> <input type="button" value="Return"/>		T-Total 4.6 h		Normal	Export Limit	19-07-20 15: 47	<ol style="list-style-type: none"> Turn on the "Limit enable". Select the "Current mode". Please set export limitation current value according to practical situation. Click "OK" when completing the setting. 																								
	Graph	Setting	Run-Info	About																																																		
	Limit enable: <input checked="" type="checkbox"/> On <input type="checkbox"/> Off		Power 1230W																																																			
	Limit mode: Current mode		E-Today 11.33 kWh																																																			
	Limit power: 0 %		E-Total 14.35 kWh																																																			
	Limit current: 0.0A		T-Today 1.7 h																																																			
	<input type="button" value="OK"/> <input type="button" value="Return"/>		T-Total 4.6 h																																																			
	Normal	Export Limit	19-07-20 15: 47																																																			

Note: 1. Power mode and current mode could be alternatively selected;
2. When the setting is completed, the export limitation system will begin to run.