



Single-phase Solar Hybrid Inverter

□ 8 kW - 12 kW



User Manual

Version 1.0

Trademarks

 and other Yinergy trademarks used in this manual are owned by Yinergy. Digital Power Technology Co., Ltd. All other trademarks or registered trademarks mentioned in this manual are the property of their respective owners.

Notice

Due to product version upgrades or other reasons, the content of the document may be subject to periodic updates, unless otherwise agreed, the document content cannot replace the safety precautions in the product label or user manual.

All descriptions in the documentation are intended solely as guidelines for usage.

Scope of Validity

This manual is an integral part of Three-phase Solar Hybrid Inverter. It describes the installation, electrical connection, commissioning, maintenance and troubleshooting of the product. Please read it carefully before operating.

This manual is valid for the following inverter models:

- HI5-1P10K-LV

Model Description

HI5 - 1P10K - LV

1

2

3

4

5

- | | | |
|---|--------------|---|
| 1 | Product Type | "HI" refers to Hybrid Inverter. |
| 2 | Series Type | "5" refers to "Five", implying the meaning of "give me five". |
| 3 | Grid Type | "1P" refers to Single phase. |
| 4 | Rated Power | "10K" refers to the rated output power of 10 kW. |
| 5 | Battery Type | "LV" refers to Low voltage battery. |

Target Group

Only for professionals who are familiar with local regulations, standards and electrical systems, and who have received professional training and knowledge of this product.

Symbol Description

Different levels of warning messages in this manual are defined as follows:



DANGER!

Indicates a high-level hazard that, if not avoided, will result in death or serious injury.



WARNING!

Indicates a medium-level hazard that, if not avoided, could result in death or serious injury.



CAUTION!

Indicates a low-level hazard that, if not avoided, could result in minor or moderate injury.



NOTICE

Highlight and supplement the texts. Or some skills and methods to solve product-related problems to save time.

Change History

Version 1.0 (30/09/2024)

Initial release

1	Safety	1
1.1	Safety Instruction	1
2	Production Instructions.....	2
2.1	Instructions.....	2
2.2	Features.....	2
2.3	System Connection Diagram	3
2.4	Production Overview	4
2.5	Dimension Drawing	5
3	Installation	6
3.1	Select the Mount Location	6
3.2	Mount the Inverter.....	7
3.3	Remove Terminal Protection Cover and Dust Screen	7
4	Connection	8
4.1	Three-phase Mode.....	8
4.2	Cable & Circuit Breaker Requirement.....	9
4.3	Grid & Load & Gen Connection	10
4.4	Battery Connection	11
4.5	PV Connection.....	12
4.6	Dry Contact Connection.....	12
4.7	Grounding Connection.....	13
4.8	Final Assembly.....	13
4.9	Inverter Parallel.....	14
4.9.1	Introduction.....	14
4.9.2	Precautions for Parallel Connection.....	14
4.9.3	Schematic Diagram of Parallel Connection in Single Phase.....	16
4.9.4	Schematic Diagram of Parallel Connection in Three Phase.....	19
5	Operation	24
5.1	Operation and Display Panel	24
5.2	Setting	28
5.2.1	Basic Setup.....	28
5.2.2	Work Mode Setup.....	30
5.2.3	Battery Setup.....	33
5.2.4	On Grid Setup.....	36
5.2.5	Advance Setup	37

5.2.6	Time-slot Charging / Discharging Function.....	40
5.2.7	Battery Parameter.....	41
6	Communication.....	42
6.1	Overview.....	42
6.2	USB-B Port.....	42
6.3	WIFI Port.....	43
6.4	CAN Port.....	43
6.5	RS485 Port.....	43
6.6	USB-A Port.....	44
6.7	External CT Port.....	44
6.8	Dry Contact.....	45
7	Fault and Remedy.....	46
7.1	Fault Code.....	46
7.2	Troubleshooting.....	49
7.3	Protection Function.....	51
8	Protection and Maintenance.....	51
8.1	Maintenance.....	53
9	Datasheet.....	54

1.1 Safety Instruction



DANGER!

- This chapter contains important safety instructions. Read and keep this manual for future reference.
- Be sure to comply the local requirements and regulation to install this inverter.
- Beware of high voltage. Please turn off the switch of each power sources before and during the installation to avoid electric shock.
- For optimum operation of this inverter, please follow required specification to select appropriate cable size and necessary protective device.
- Do not connect or disconnect any connections when the inverter is working.
- Do not open the terminal cover when the inverter working.
- Make sure the inverter is well grounding.
- Never cause AC output and DC input short circuited.
- Do not disassembly this unit, for all repair and maintenance, please take it to the professional service center.
- Never charge a frozen battery.
- Please keep children away from touching or mishandling the inverter.
- Please make sure that this inverter is the only input power source for the load, do not use it in parallel with other input AC power sources to avoid damage.

2.1 Instructions

HI5-1P10K-LV is a new type of solar energy storage inverter control inverter integrating solar energy storage & utility charging and energy storage, AC sine wave output. It adopts DSP control and features high response speed, reliability, and industrial standard through an advanced control algorithm.

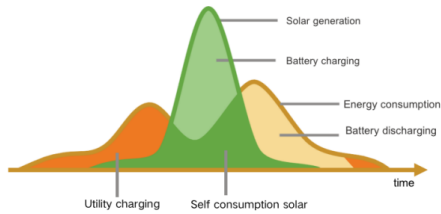

Figure 2-1 Instructions

2.2 Features

- Supports lead acid battery and li-ion battery connections.
- With a dual activation function when the li-ion battery is dormant; either main/ photovoltaic power supply access can trigger the activation of the li-ion battery.
- Support single-phase pure sine wave output.
- Supports four different voltage levels of 200\208\220\230\240Vac per phase.
- Supports two solar inputs and simultaneous tracking of two solar maximum power charging/carrying capacity functions.
- Dual MPPT with 99.9% efficiency and maximum 16A current in a single circuit, perfectly adapted to high power modules.
- 2 charging modes are available: solar only, mixed mains/PV charging.
- With the time-slot charging and discharging setting function, you can set the time period for cutting in/out of mains charging and switch the time period between battery discharging and mains bypass power supply mode.
- Energy saving mode function to reduce no-load energy losses.
- With two output modes of utility bypass and inverter output, with uninterrupted power supply function.
- LCD large screen dynamic flow diagram design, easy to understand the system data and operation status.
- 360° protection with complete short circuit protection, over current protection, over under voltage protection, overload protection, backfill protection, etc.
- Support CAN, USB, and RS485 communication..

2.3 System Connection Diagram

The diagram below shows the system application scenario of this product. A complete system consists of the following components:

- 1 **PV modules:** converts light energy into DC energy, which can be used to charge the battery via an inverter or directly inverted into AC power to supply the load.
- 2 **Utility grid or generator:** connected to the AC input, either of the connected utility and generator can charge the battery while supplying the load. When the batteries and photovoltaic modules supply the load, the system can operate without the utility or generator.
- 3 **Battery:** The role of the battery is to ensure the normal power supply of the system loads in case of insufficient photovoltaic and no utility power.
- 4 **Home load:** connects to a variety of home and office loads including refrigerators, lamps, TVs, fans, air conditioners and other AC loads.
- 5 **Inverter:** it is the energy conversion device of the whole system.

The actual application scenario determines the specific system wiring method.

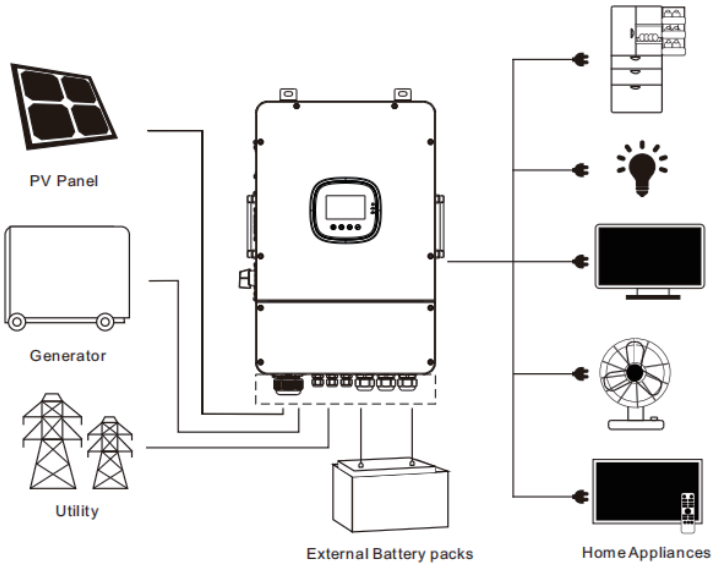
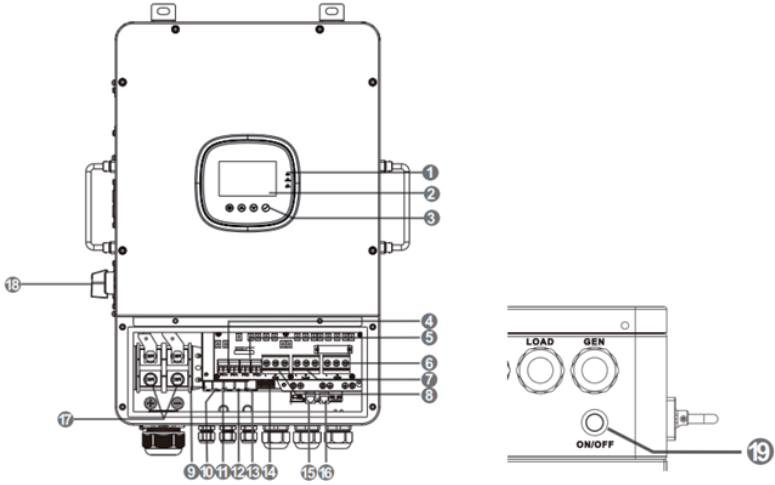

Figure 2-2 System Connection Diagram

2.4 Production Overview



- | | |
|-----------------------------|---------------------------------|
| ① LED Indicators | ⑪ RS485 port |
| ② LCD Screen | ⑫ CAN port |
| ③ Touchable key | ⑬ External CT port |
| ④ PV1 Terminals | ⑭ Dry contact |
| ⑤ PV2 Terminals | ⑮ Parallel communication B port |
| ⑥ Generator terminals (L+N) | ⑯ Parallel communication A port |
| ⑦ Load terminals (L+N) | ⑰ Battery terminal |
| ⑧ Utility terminals (L+N) | ⑱ ON/OFF rocker switch |
| ⑨ USB-B port | ⑳ USB-A port |
| ⑩ WIFI port | |

Figure 2-3 Appearance

2.5 Dimension Drawing

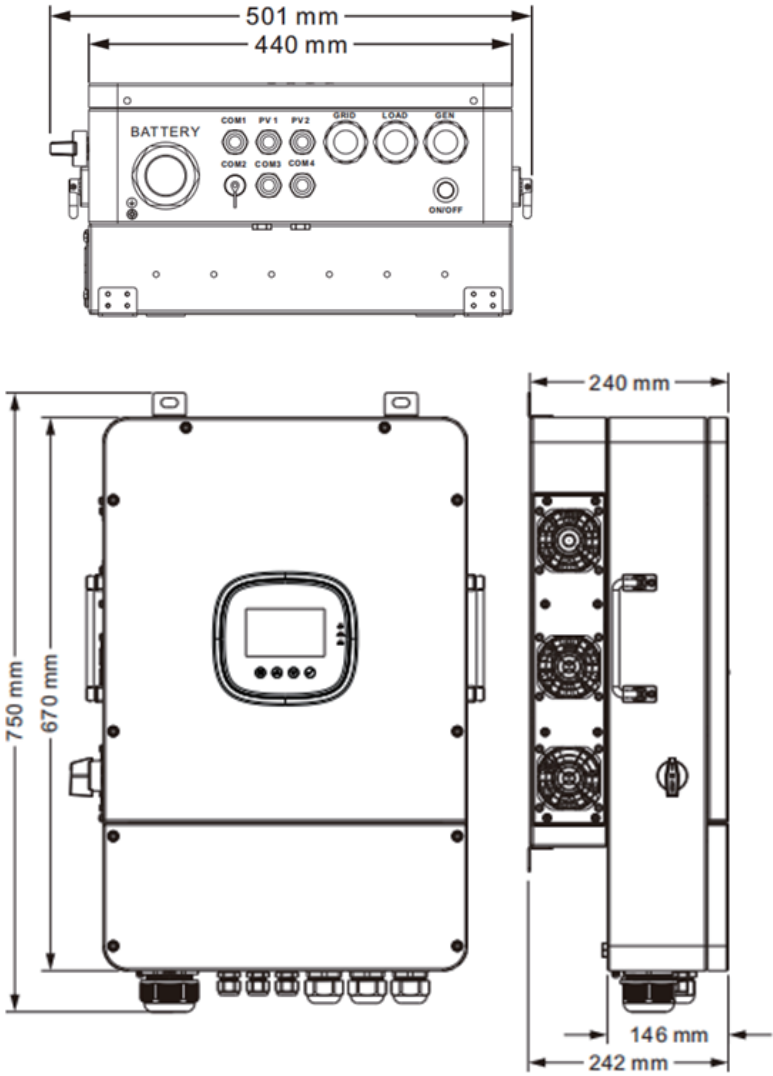

Figure 2-4 Dimensions

3.1 Select the Mount Location

HI5-1P10K-LV can be used outdoors (protection class IP65). Please consider the followings before selecting the location.

- Choose the solid wall to install the inverter.
- Mount the inverter at eye level.
- Adequate heat dissipation space must be provided for the inverter.
- The ambient temperature should be between $-25 \sim 60 \text{ }^{\circ}\text{C}$ ($-13 \sim 140 \text{ }^{\circ}\text{F}$) to ensure optimal operation.

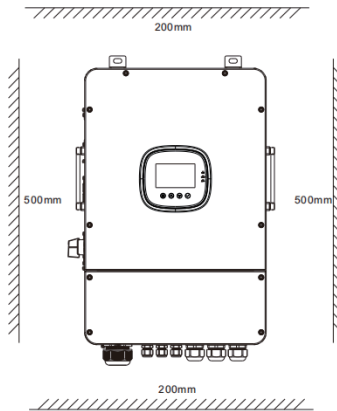

Figure 3-1 Mount Location



DANGER!

- Do not install the inverter where highly flammable materials are nearby.
- Do not install the inverter in potential explosive areas.
- Do not install the inverter with lead-acid batteries in a confined space.



CAUTION!

- Do not install the inverter in direct sunlight.
- Do not install or use the inverter in a humid environment.

3.2 Mount the Inverter

Punch 4 mounting holes in the wall with an electric drill according to the specified size, and insert 4 M8 × 60 expansion screws above.

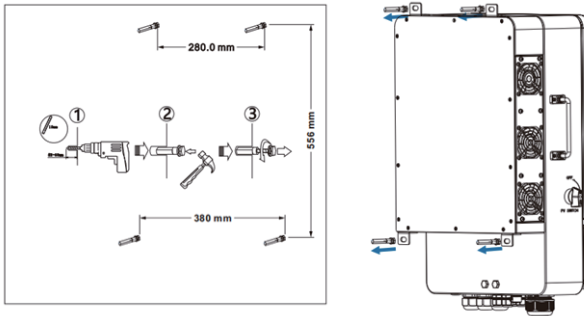

Figure 3-2 Drilling

3.3 Remove Terminal Protection Cover and Dust Screen

Using a screwdriver, remove the terminal protection cover and dust screen.

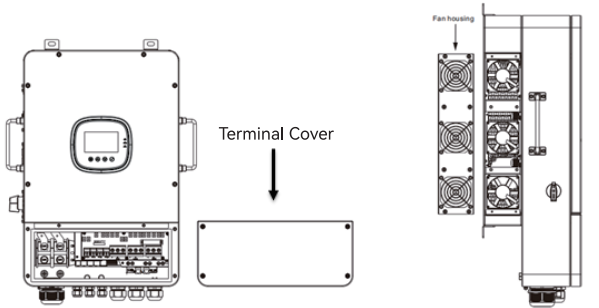

Figure 3-3 Remove Cover and Screen

NOTICE

- When using the device in areas with poor air quality, the fan cover is easily blocked by air particles. Please disassemble and clean the fan periodically to avoid affecting the internal air flow rate of the inverter, which may trigger an over-temperature protection fault (19/20 fault) affecting the use of the power supply and the service life of the inverter.

4.1 Three-phase Mode

AC Output

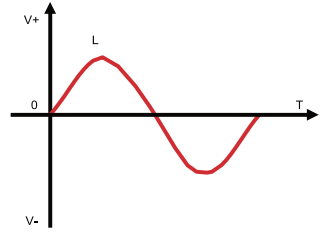
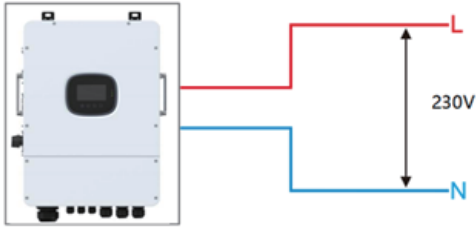

Item	Description
Applicable Model	HI5-1P10K-LV
Output Voltage Range (L-N)	200 ~ 240 Vac, 230 Vac default

i NOTICE

- Users can change the output phase mode and output voltage by setup menu.
- The output voltage can be set from 200 V to 240 V.

Single-Phase mode

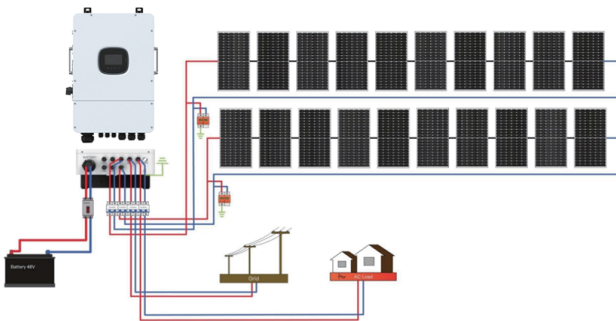

Figure 4-1 Single-phase Mode Connection

4.2 Cable & Circuit Breaker Requirement

- PV Input

Models	Cable Diameter	Max. PV Input Current	Circuit Breaker Spec
HI5-1P10K-LV	5 mm ² / 10 AWG	22 A	2P - 25 A

- AC Input

Models	Cable Diameter	Max. Input Current	Circuit Breaker Spec
HI5-1P10K-LV	13 mm ² / 6 AWG (L / N)	63 A	2P - 63 A

- Generator

Models	Cable Diameter	Max. Input Current	Circuit Breaker Spec
HI5-1P10K-LV	13 mm ² / 6 AWG (L / N)	63 A	2P - 63 A

- Battery

Models	Cable Diameter	Max. Battery Current	Circuit Breaker Spec
HI5-1P10K-LV	42 mm ² / 1 AWG	230 A	2P - 250 A

- AC Output

Models	Output Model	Cable Diameter	Circuit Breaker Spec
HI5-1P10K-LV	Single phase	13 mm ² / 6 AWG (L / N)	2P - 63 A

i NOTICE

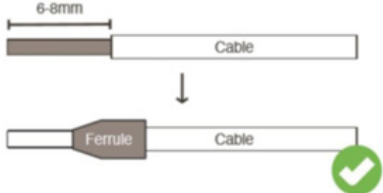
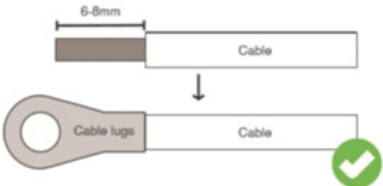
<ul style="list-style-type: none">• PV input, AC input, AC output<ol style="list-style-type: none">1 Use a stripper to remove the 6 ~ 8 mm insulation of the cable.2 Fixing a ferrule at the end of the cable (ferrule needs to be prepared by the user).	
<ul style="list-style-type: none">• Battery<ol style="list-style-type: none">1 Use a stripper to remove the 6 ~ 8 mm insulation of the cable.2 Fixing cable lugs that supply with the box at the end of the cable.	

The wire diameter is for reference only. If the distance between the PV array and the inverter or between the inverter and the battery is long, using a thicker wire will reduce the voltage drop and improve the performance of the system.

4.3 Grid & Load & Gen Connection

Connect the live, neutral and ground cables in the position and order of the cables as shown in the diagram below.

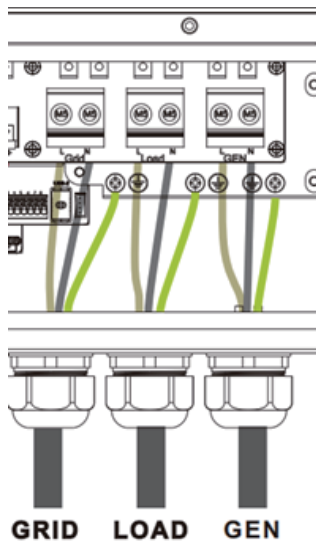

Figure 4-2 Grid & Load & Gen Connection

DANGER!

- Before connecting the AC input and output, the circuit breaker must be disconnected to avoid the risk of electric shock and must not be operated with electricity.
- Please check that the cable used is sufficient for the requirements, too thin, poor quality cables are a serious safety hazard.

4.4 Battery Connection

Connect the positive and negative cable of the battery according to the diagram below.

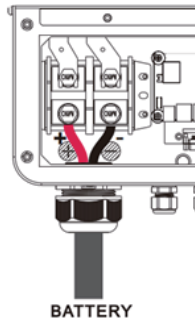

Figure 4-3

Battery Connection

DANGER!

- Before connecting the battery, the circuit breaker must be disconnected to avoid the risk of electric shock and must not be operated with electricity.
- Please ensure that the positive and negative terminals of the batteries are correctly connected and not reversed, otherwise the inverter may be damaged.
- Please check that the cable used is sufficient for the requirements, too thin, poor quality cables are a serious safety hazard.

4.5 PV Connection

Connect the positive and negative wires of the two strings of PV according to the diagram below.

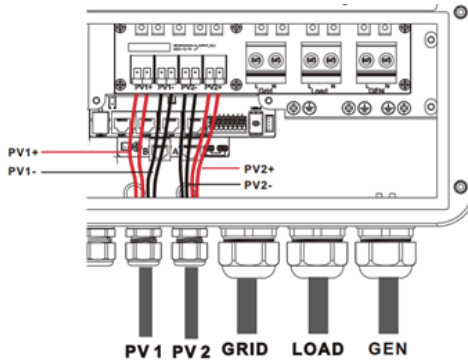

Figure 4-4 PV Connection



DANGER!

- Before connecting PV, the circuit breaker must be opened to avoid the risk of electric shock and must not be operated with electricity.
- Please make sure that the open circuit voltage of the PV modules in series does not exceed the Max. Open Circuit Voltage of the inverter (this value is 500V), otherwise the inverter may be damaged.

4.6 Dry Contact Connection

Use a small screwdriver to push back the direction indicated by the arrow, then insert the communication cable into the dry junction port. (Communication cable diameter 0.2 ~ 1.5 mm²).

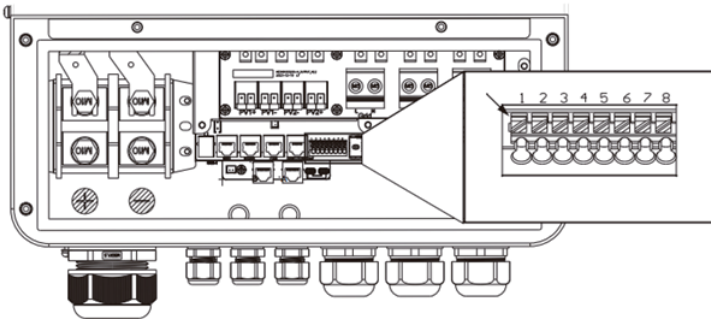

Figure 4-5 Dry Contact Connection

4.7 Grounding Connection

Please make sure the grounding terminal connect to the Grounding Bar.

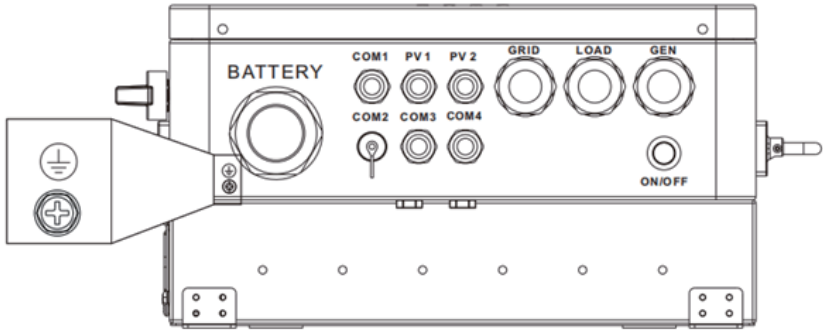

Figure 4-6 Grounding Connection

i NOTICE

- The grounding cable should have a diameter of not less than 4 mm² and be as close as possible to the grounding point.

4.8 Final Assembly

After ensuring that the wiring is reliable and the wire sequence is correct, install the terminal protection cover in place.

- Step 1:** Close the circuit breaker of the battery.
- Step 2:** Press the rocker switch on the bottom of inverter, the screen and indicators light up to indicate that the inverter has been activated.
- Step 3:** Sequential close of the circuit breakers for PV, AC input and AC output.
- Step 4:** Start the loads one by one in order of power from small to large.

4.9 Inverter Parallel

4.9.1 Introduction

- 1 Up to six units connected in parallel.
- 2 When using the parallel operation function, the following connecting lines (package accessories) shall be firmly and reliably connected:



Figure 4-7 Parallel Communication Cable

4.9.2 Precautions for Parallel Connection



WARNING!

1 PV Connection

When connected in parallel, the PV arrays of each machine must be independent and the PV arrays of PV1 and PV2 of each machine must also be independent.

2 Battery Wiring

Parallel connection in single or three-phase: ensure that all solar storage inverters are connected to the same battery, with BAT + connected to BAT + , BAT - connected to BAT - , and that the connection is correct with the same wiring length and line diameter before power on, so as to avoid the abnormal operation of parallel system output caused by wrong connection.

3 Load Wiring

Parallel connection in single phase: ensure L-to-L, N-to-N and PE-to-PE connection for all solar storage inverters, and that the connection is correct with the same wiring length and line diameter before power on, so as to avoid the abnormal operation of parallel system output caused by wrong connection. For specific wiring, please refer to Wiring Diagram.

Parallel connection in three-phase: ensure N-to-N and PE-to-PE connection for all solar storage inverters. The L lines of all inverters connected to the same phase need to be connected together. But L lines of different phases cannot be joined together. Other connection precautions are the same as parallel connection in single phase. For specific wiring, please refer to Wiring Diagram.



WARNING!

4 Grid Wiring

Parallel connection in single phase: ensure L-to-L, N-to-N and PE-to-PE connection for all solar storage inverters, and that the connection is correct with the same wiring length and line diameter before power on, so as to avoid the abnormal operation of parallel system output caused by wrong connection. Meanwhile, it is not allowed to have multiple different AC source inputs to avoid damage to the external equipment of the inverter. The consistency and uniqueness of AC source input shall be ensured. For specific wiring, please refer to Wiring Diagram.

Parallel connection in three-phase: ensure N-to-N and PE-to-PE connection for all solar storage inverters. The L lines of all inverters connected to the same phase need to be connected together. But L lines of different phases cannot be joined together. Other connection precautions are the same as parallel connection in single phase. For specific wiring, please refer to Wiring Diagram.



WARNING!

5 Wiring of Parallel Communication Line

Our parallel communication cable is a shielded 10 Pin network connection cable, which can be used for single-phase or three-phase parallel connection. Each machine must be connected with one out and one in. This means that the machine "Parallel_A" is connected to the machine to be parallelized "Parallel_B", and that the machine "Parallel_A" is not allowed to connect to the "Parallel_B". "Parallel_B" or "Parallel_A" is connected to the machine to be parallelized "Parallel_A". At the same time, the parallel communication cable of each machine should be fastened with 10Pin network connection cable to avoid disconnection or poor contact of the parallel communication cable, which may cause abnormal operation or damage to the system output.

- 6 Before and after connecting the system, please check the following system wiring diagrams in detail to ensure that all wiring is correct and reliable before powering on.
- 7 After the system is wired, powered on and in normal operation, if a new inverter needs to be connected, make sure to disconnect the battery input, PV input, AC input and AC output, and that all solar storage inverters are powered off before reconnecting into the system.

4.9.3 Schematic Diagram of Parallel Connection in Single Phase

The parallel communication line of the solar storage inverter needs to be locked with screws after connecting.

The parallel mode need to set as "single phase parallel" for each inverter



Figure 4-8 Parallel Mode

In case of parallel operation with multiple inverters, the schematic diagram of parallel connection is as follows:

Two Units Connected in Parallel

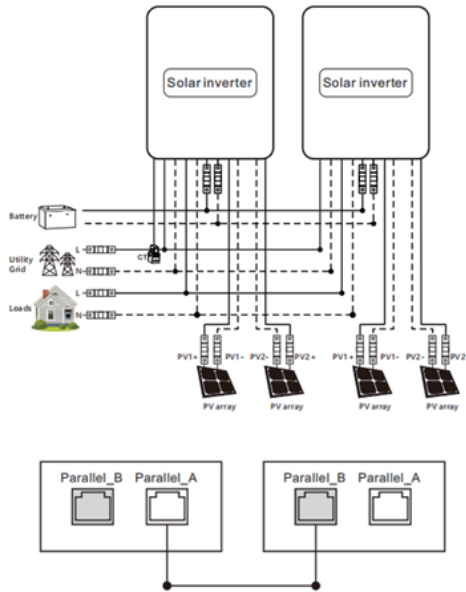

Figure 4-9 Two Units

Three Units Connected in Parallel

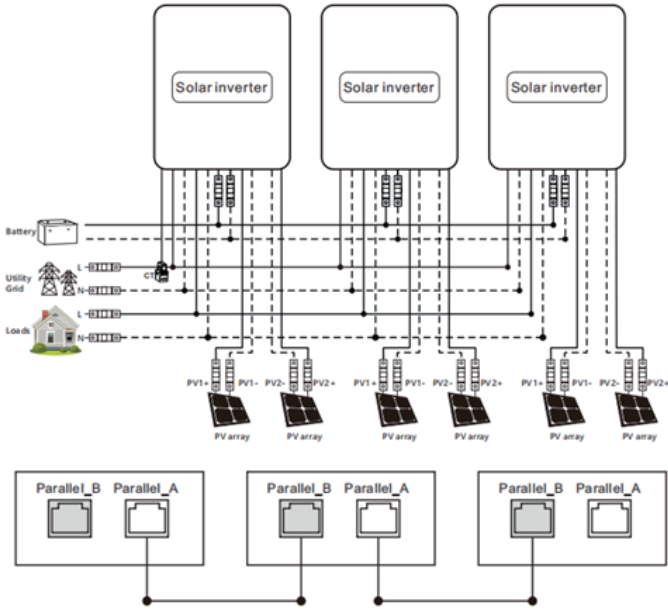

Figure 4-10 Three Units

Four Units Connected in Parallel

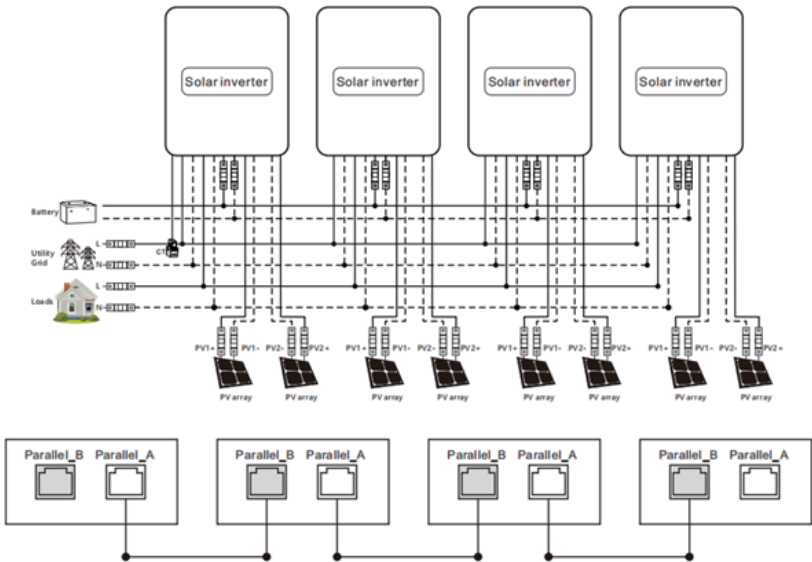

Figure 4-11 Four Units

Five Units Connected in Parallel

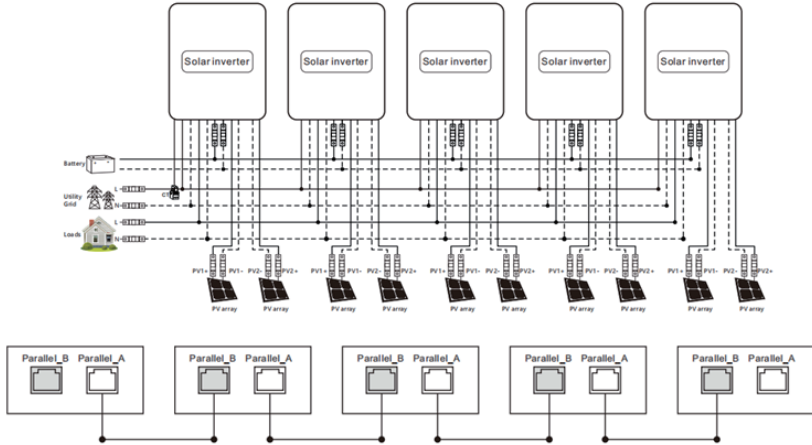

Figure 4-12 Five Units

Six Units Connected in Parallel

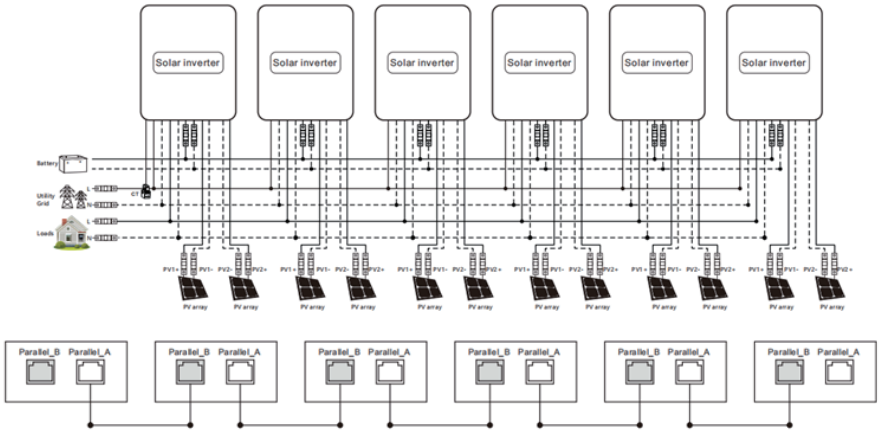

Figure 4-13 Six Units

4.9.4 Schematic Diagram of Parallel Connection in Three Phase

- 1 The parallel communication line and current sharing detection line of the solar storage inverter need to be locked with screws after connecting.
- 2 In case of parallel operation with multiple inverters, the schematic diagram of parallel connection is as follows:

Parallel Operation in three phase:

All inverters in P1 must be set as [three phase A]

All inverters in P2 must be set as [three phase B]

All inverters in P3 must be set as [three phase C]

When the output phase voltage is 230 Vac

At present the line voltage between the live wire L1 in phase 1 and the live wire L2 in phase 2 is $230 \times 1.732 = 398\text{Vac}$, and similarly the line voltage

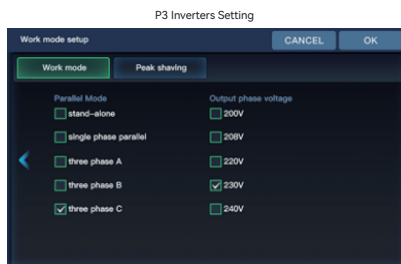
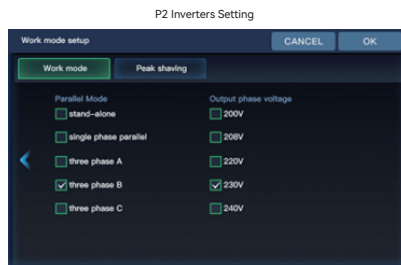

Figure 4-14 Parallel Operation

Three Units Connected in Three Phase: 1+1+1 System:

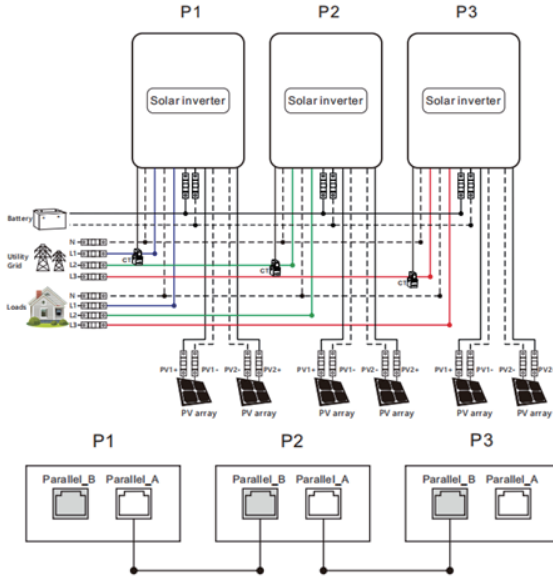

Figure 4-15 Three Units-3P

Four Units Connected in Three Phase: 2+1+1 System:

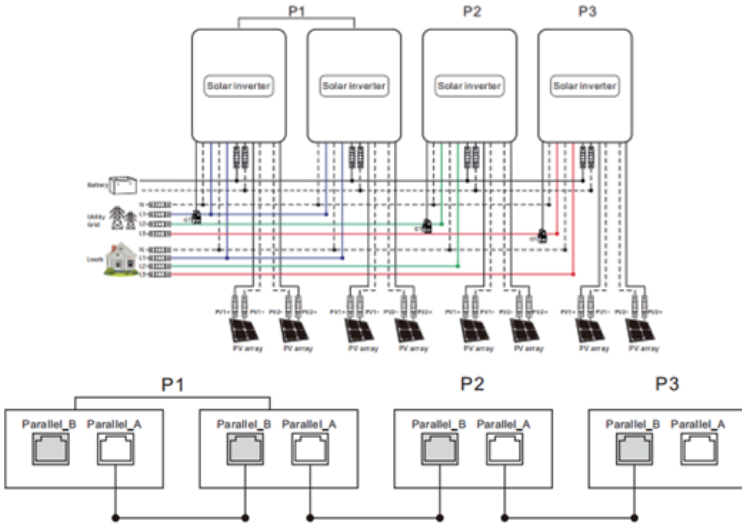

Figure 4-16 Four Units-3P

Five Units Connected in Three Phase: 3+1+1 System:

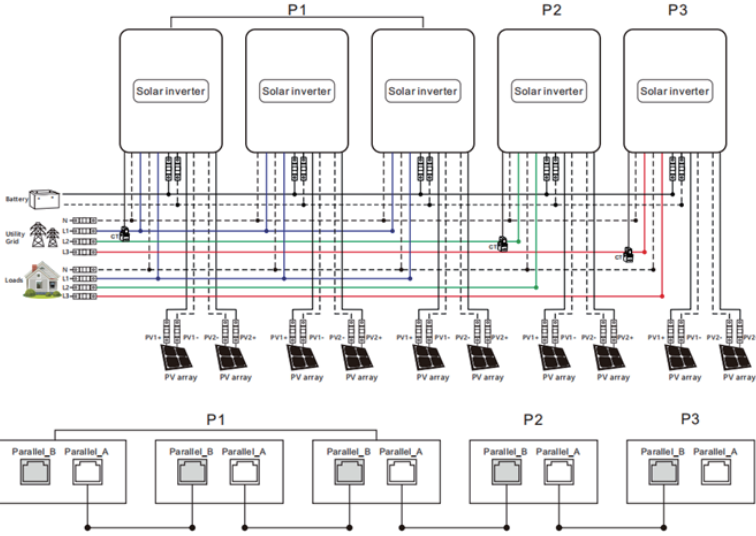

Figure 4-17 Five Units-3P-1

Five Units Connected in Three Phase: 2+2+1 System:

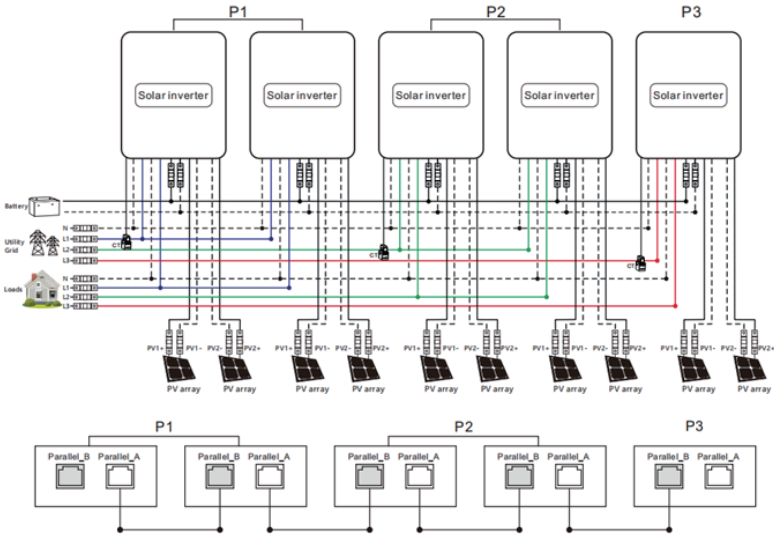

Figure 4-18 Five Units-3P-2

Six Units Connected in Three Phase: 2+2+2 System:

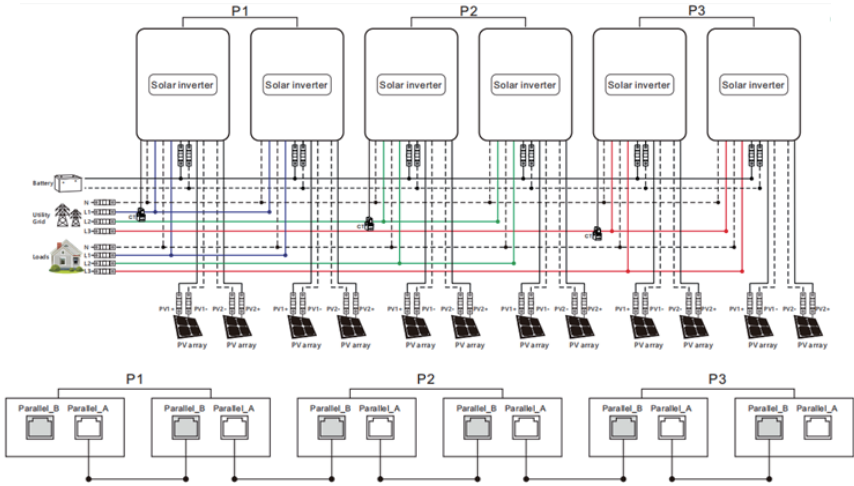

Figure 4-19 Six Units-3P-1

Six Units Connected in Three Phase: 3+2+1 System:

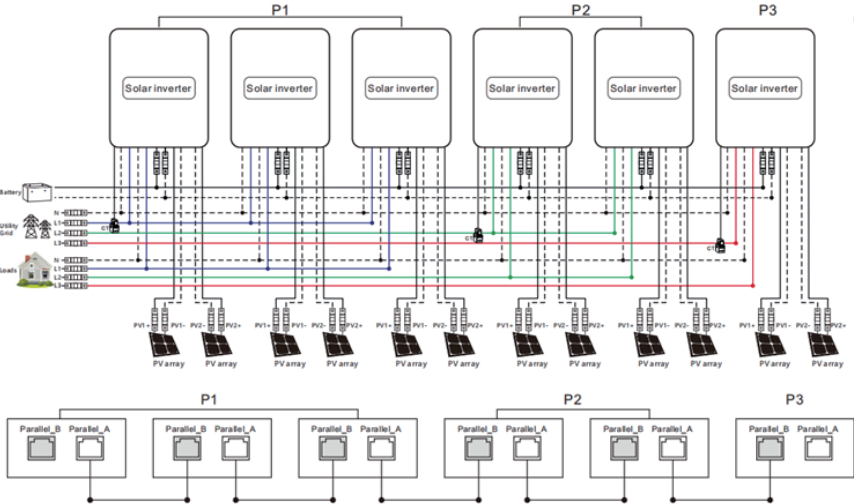

Figure 4-20 Six Units-3P-2

Six Units Connected in Three Phase: 4+1+1 System:

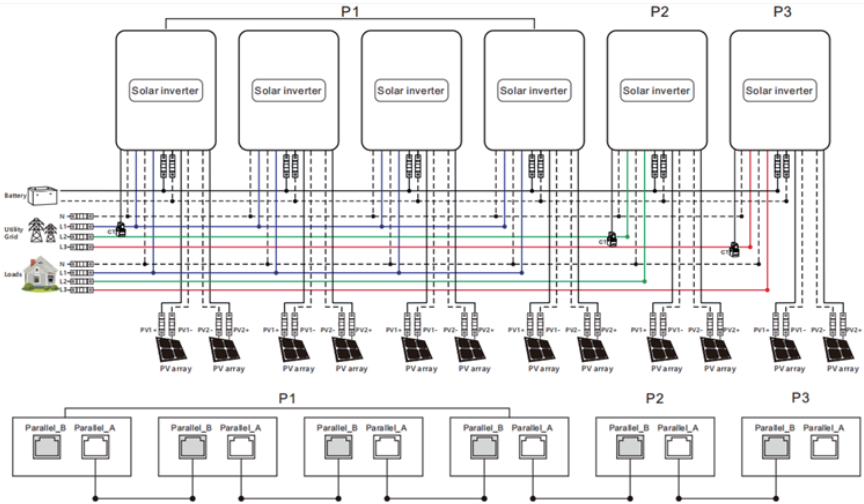

Figure 4-21 Six Units-3P-3

NOTICE

- 1 Before starting up and running, please check whether the connection was correct to avoid any abnormalities in the system.
- 2 All wiring must be fixed and reliable to avoid wire drop during use.
- 3 When the AC output is wired to the load, it shall be properly wired according to the requirements of the electrical load equipment to avoid damage to the load equipment.
- 4 Setting item “output phase voltage setting” needs to be set consistently or only for the master. When paralleling, the voltage set by the master will prevail, and the master will be forced to rewrite the rest of the slaves to be consistent. This option can be set in standby mode only.
- 5 Machine factory default for single machine mode, if you use parallel or three-phase function, you need to set the “Parallel mode” item parameters through the screen. The setting method is: power on one machine at a time, the rest of the machine off, and then set the “Parallel mode” item parameters according to the site system operation mode. After this machine is set successfully, turn off the machine switch and wait for the machine to be powered down, then set the rest of the machines in turn until all machines are set, and then all machines are powered up again at the same time and enter the working state.
- 6 After the system runs, the output voltage is measured correctly, and then the load setting is connected.

5.1 Operation and Display Panel

The operation and display panel below includes 1 LCD screen, 3 indicators, 4 touchable keys.

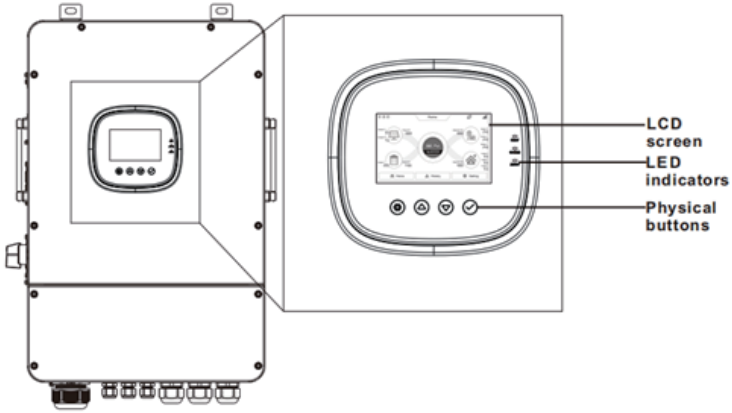





Figure 5-1 Operation Panel

- Keys

Keys	Description
	To enter / exit the setting menu
	To last selection
	To next selection
	To confirm / enter the selection in setting menu

- LED Indicators

Indicators	Color	Description
FAULT	Red	Flash: error occur
CHARGE	Yellow	Continued: charging complete
		Flash: charging

Indicators	Color	Description
AC / INV	Green	Continued: utility grid by-pass output
		Flash: inverter output

- Display Panel

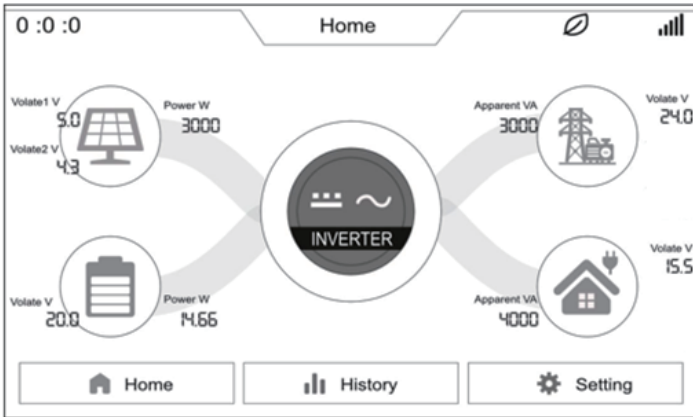

Figure 5-2 Display Panel

Icon	Description	Icon	Description
	Solar panel		Load
	Battery		Grid or Generator
	Home page		Inverter is working
	History data		Setting
0:0:0	Local time		The buzzer is silent
	BMS Communicate Status		The energy direction

- View Real-time Data

On the LCD home screen, click the inverter icon, battery icon, mains icon, load icon and photovoltaic icon to view the real-time data of the machine.

System Data			
No.	Item	No.	Item
1	Machine state	7	SN Code
2	MCU1 version	8	Min Version Number
3	LCD version	9	Rated Power
4	MCU2 version	10	RS485 Address
5	Outside Temperature	11	Transformer Temperature
6	Inverter Voltage	12	Inverter Current

Battery Data			
No.	Item	No.	Item
1	SOC (Percentage of remaining battery capacity)	5	Discharge current
2	Battery voltage	6	BMS protocol
3	Battery current	7	Battery type
4	Battery power (Battery charging and discharging power)	8	Battery Charge Status

Grid Data			
No.	Item	No.	Item
1	Voltage	5	Current
2	Active Power	6	Apparent Power
3	Frequency	7	Mains Charging Current
4	CT Power		

Load Data

No.	Item	No.	Item
1	Voltage	5	Current
2	UPS Load Active Power	6	UPS Load Apparent Power
3	Frequency	7	Load Rate
4	BUS Voltage		

PV Data

No.	Item	No.	Item
1	PV1 Voltage	5	PV2 Current
2	PV1 Current	6	PV2 Power
3	PV1 Power	7	Generate energy total
4	PV2 Voltage		

5.2 Setting

Operating instructions: Click on the settings in the menu bar at the bottom of the screen to enter the setup interface, including the basic settings, work mode setup, battery setup, on grid setup, advanced setup of the five major setup items.

5.2.1 Basic Setup

5.2.1.1 Display Setup

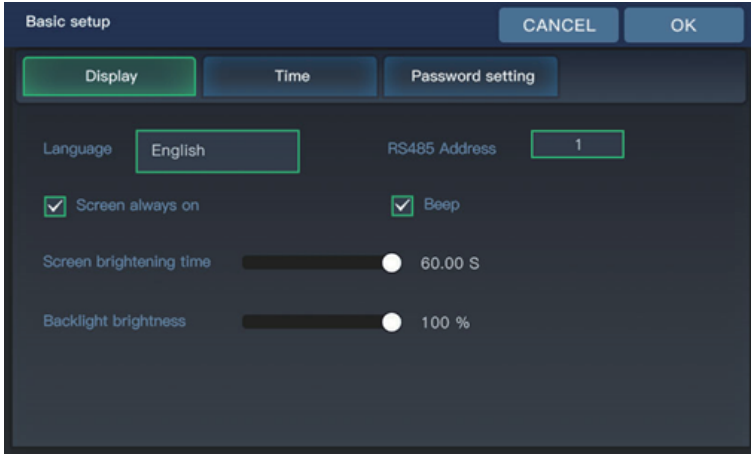

Figure 5-3 Display

Parameter	Meaning	Description
Language		Currently only English
RS485 Address		Display and current inverter RS485 address, range 1-254
Screen always on		Selectable whether the screen is always on or not
Beep		You can choice whether enable the Beep alarm
Screen brightening time		Setting range 0-60 s
Backlight brightness		0-100%

5.2.1.2 Time Setup

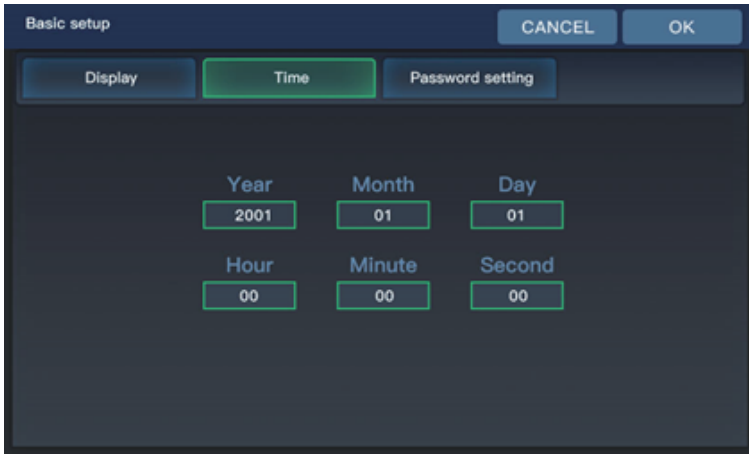

Figure 5-4 Time Setup

5.2.1.3 Password Setting (Password is required to access the Grid Settings and Advanced Settings)

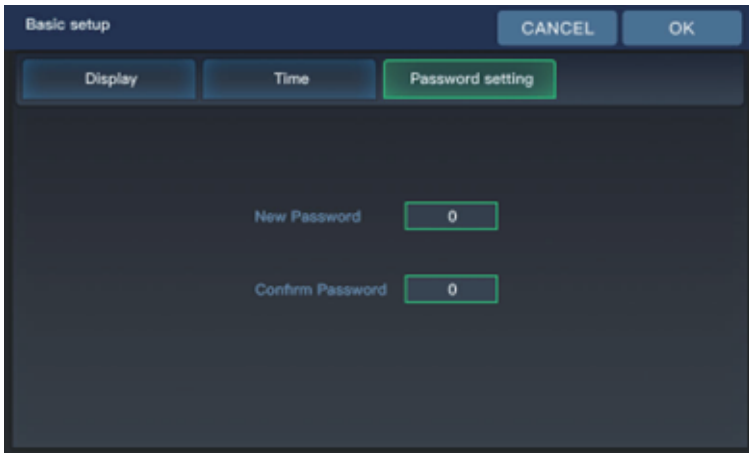

Figure 5-5 Password Setting

Default password is "00000".

Password setting value range: 0-65535.

5.2.2 Work Mode Setup

5.2.2.1 Work Mode

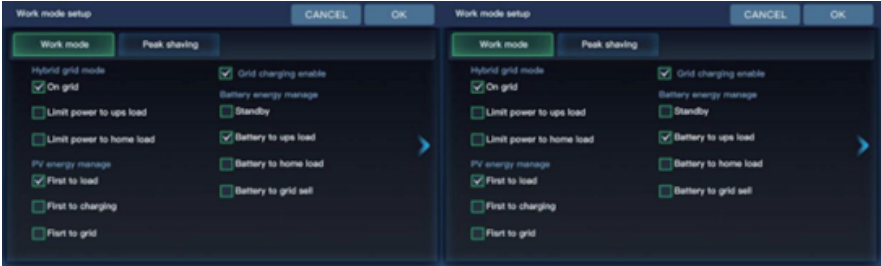

Figure 5-6 Work Mode

Home Load: connected to the GRID port of the machine, requires external CT for monitoring.

Ups Load: connected to the LOAD port of the machine.

Parameter Meaning	Option	Description
Hybrid grid mode	On grid	Direct grid connection of excess PV energy
	Limit Power to ups load	Ups load backflow prevention, photovoltaic or battery energy is only for the ups load, excess energy will not be connected to the grid
	Limit Power to home load	Home load anti-backflow, solar or battery energy is only supplied to the home load, excess energy will not be connected to the grid.
PV energy manage	First to Load	<ul style="list-style-type: none"> When mixed grid mode is set to "Limit Power to ups load" or when CT is not connected, the following load refers to the ups load. When mixed grid mode is set to "Limit Power to home load/On grid" and CT is connected, the following load refers to the ups load plus the home load. PV power supply logic: load-charge-grid connection
	First to charging	PV power supply logic: charge-load-grid connection
	First to grid	PV power supply logic: load-grid connection-charge
Grid charging enable	Selectable grid participation in battery charging	

Parameter Meaning	Option	Description
Battery energy manage	Standby	The battery does not discharge, and the battery is discharged only when the working state is off the grid.
	Battery to ups load	When the PV power is less than the UPS load power, the battery discharge is added.
	Battery to home load	The battery can supply the power to Home load
	Battery to grid sell	The battery can supply the power to grid.
Parallel mode	Stand-alone	
	Single-phase Parallel	
	Three Phase A	Three-phase parallel connection setting
	Three Phase B	All machines in phase 1 must be set as [three phase A]
	Three Phase C	All machines in phase 2 must be set as [three phase B] All machines in phase 3 must be set as [three phase C] When the output voltage is 230Vac At present the line voltage between the live wire L1 in phase 1 and the live wire L2 in phase 2 is $230 \times 1.732 = 398\text{Vac}$, and similarly the line voltage
Output phase voltage	Settable: 200V, 208V, 220V, 230V, 240V.	

5.2.2.2 Peak Shaving



Figure 5-7 Peak Shaving

Parameter	Meaning	Description
	Time charging/ discharging enable	Select whether to turn on timed charging and discharging
	Start/End Time	Setting the time period for timed charging and discharging
	Stop SOC	Setting the battery charging cut-off SOC value and the cut-off SOC value for discharging during the timed charging and discharging time period (during BMS communication)
	Stop Volt	Setting the battery charging cut-off voltage value and discharging cut-off voltage value during the timed charging and discharging time period (when the BMS is not communicating)
	Max Power	Setting the battery charging power and discharging power during the timed charging and discharging time period.
	Grid charge	When setting the timed charge, select the grid to charge the battery
	Generator	When setting the timed charge, select the generator to charge the battery

5.2.3 Battery Setup

5.2.3.1 Battery Type

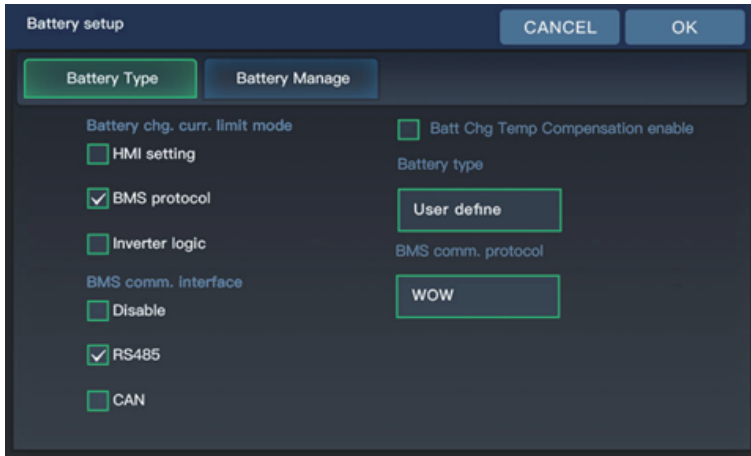

Figure 5-8 Battery Type

Parameter Meaning	Option	Description
Battery chg. curr. limit(Valid for BMS communication)	HMI	Maximum battery charging current is limited according to the inverter battery charging current setting value.
	BMS	Maximum battery charging current is limited by the current limit value of the BMS.
	Inverter	Maximum battery charging current is limited by the machine's derating logic.
BMS comm. interface	Disable	BMS does not communicate
	RS485	BMS RS485 communication function
	CAN	BMS CAN communication function
Battery Temperature Compensation	Select whether to turn on temperature compensation	

Parameter Meaning	Option	Description
Battery Type	USER	User customizable to set all battery parameters
	SLd	Sealed Lead Acid Battery
	FLd	Open-ended lead-acid batteries
	GEL	gel lead-acid battery
	LFP/14/ 15/ LFP 16	Li-FePO4/14/15/16, corresponding to Li-FePO4 14 string, 15 string, 16 string
	N13/ N14	Ternary lithium batteries, N13/N14, corresponding to ternary lithium batteries 13 string, 14 string
	No battery	Without battery
BMS comm. protocol	<p>When the BMS port selection setting item = 485 or CAN, you need to select the corresponding lithium battery manufacturer brand for communication:</p> <p>1 : PACE-PACEEX 2 : RUDA-Ritar 3 : AOGUAN-==ALLGRAND BATTERY 4 : OULITE-OLITER 5 : CEF-CHANGFENG TECNOLOGY 6 : XINWANGDA -SUNWODA 7 : DAQIN -DAKING 8 : WOW 9 : PYL-PYLONTECH 10 : MIT-FOXESS 11: XIX-XYE 12: POL-POWERMR 13: GUOX-Gotion 14: SMK-SMK 15: VOL-WEILAN 16:UZE-YUZE</p>	

5.2.3.2 Battery Manage

Battery setup		CANCEL	OK
Battery Type		Battery Manage	
Maximum chg. voltage	54.0V	Maximum chg. current	120A
Batt. Recharging voltage	50.4V	Max. chg. curr. by Grid	120A
Battery curr. stop chg.	3.0A	Bat. SOC stop chg.	100%
Stop discharge voltage	43.6V	Stop dchg. delay time	30S
Eod recovery voltage	49.6V	Batt. SOC stop dchg.	5%
Battery under volt. alarm	46.4V	Batt. SOC low alarm	15%
Battery volt. to line	46V	Battery SOC to line	10%

Figure 5-9 Battery Manage

Parameter Meaning	Description
Maximum chg. voltage	When the battery is charging, the voltage reaches the value to stop charging
Batt. Recharging voltage	When the battery is fully charged, the inverter stops charging and resumes charging when the battery voltage falls below this voltage value.
Battery curr. stop chg.	When the charging current falls below this setting, the battery will stop charge
Stop discharge Voltage	When the battery is discharged, the voltage reaches the value and stops discharging.
Eod recovery voltage	When the battery low voltage disconnects the inverter output, the battery voltage needs to be greater than this setting to restore the battery inverter AC output.
Battery under volt. alarm	Battery under-voltage alarm point, when the battery voltage is lower than the judgment point, the under-voltage alarm will be reported and the output will not be turned off.
Maximum chg. current	Setting the amount of current when charging the battery
Max. chg. curr. by Grid	When using mains charging, set the size of the battery mains charging current (the value is the battery current, DC)
Bat.SOC stop chg.	"Charging will stop when the SOC value reaches this set point (effective when BMS communication is normal)."
stop. dchg. delay time	When the battery voltage reaches the "Stop Discharge Voltage" setting, the inverter output is shut down with a delay.
Batt. SOC stop dchg.	When the SOC value reaches this setting, an error 32 is reported and the inverter output is shut down (valid when BMS communication is normal).
Batt SOC low alarm	SOC value up to this setting will report 30 faults. The inverter output will not shut down and the fault disappears if the SOC value exceeds 5% of the set value. (Valid when BMS communication is normal)
Batt.volt.stop dchg to grid	When the battery reaches the voltage value, it switches to the grid supply
Batt.soc.stop dchg to grid	When the battery reaches the SOC value, it is converted to mains power supply (effective for BMS communication).

5.2.4 On Grid Setup

To enter this setting, you need to enter the password set by the user, the default password is "00000".

5.2.4.1 Basic



Figure 5-10 Basic Setup

Parameter	Meaning	Description
Grid standard		Europe: EN50549-1
		South Africa: NRS-097
		UKJ: G99
		Other regions: GNL
Grid Frequency		Selection of local grid frequency, 50 Hz / 60 Hz
CT ratio		When connecting an external CT, enter the ratio on the CT specification.
Sell power Max		On grid power
Buy power Max		Maximum power drawn from the grid. If the grid charging power + load power exceeds this setting, the machine reduces the charging power. (Setting range: 0 to rated power)
Zero-export power		Error calibration power in the case of backflow prevention, recommended setting 20 - 100 W

5.2.5 Advance Setup

To enter this setting, you need to enter the password set by the user, the default password is "00000".

5.2.5.1 Generator

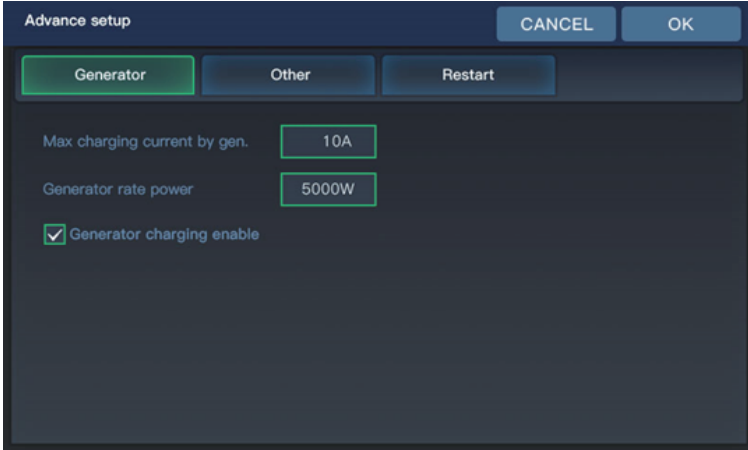

Figure 5-11 Generator

Parameter Meaning	Description
Max charging current by gen.	Maximum battery charging current during generator charging
Generator rate power	Setting the power of the generator up to the rated power of the inverter
Generator charging enable	Setting whether the generator is charged or not

5.2.5.2 Other

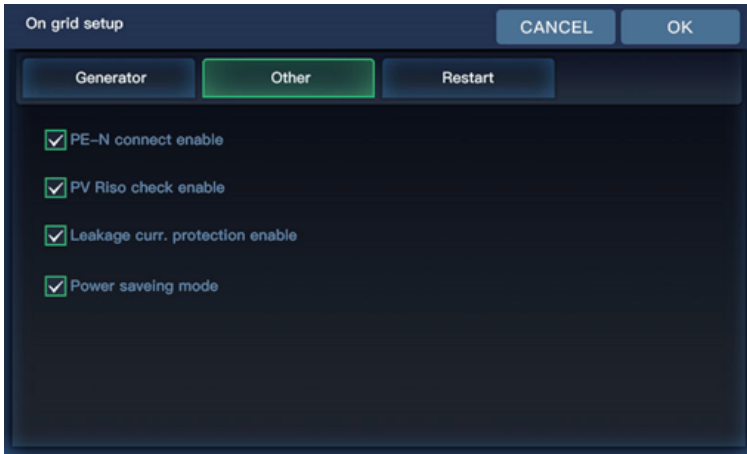

Figure 5-12 Other

Parameter	Meaning	Description
PE-N connect enable		Enable automatic switching of PE-N connections
PV Riso check enable		Enable PV insulation impedance detection
Leakage curr. protection enable		Enable leakage current protection
Power saving mode		After turning on the energy-saving mode, if the load is empty or less than 25 W, the inverter output will be shut down after a delay of 5min; when the load is more than 40W, the inverter will start automatically.

5.2.5.3 Restart

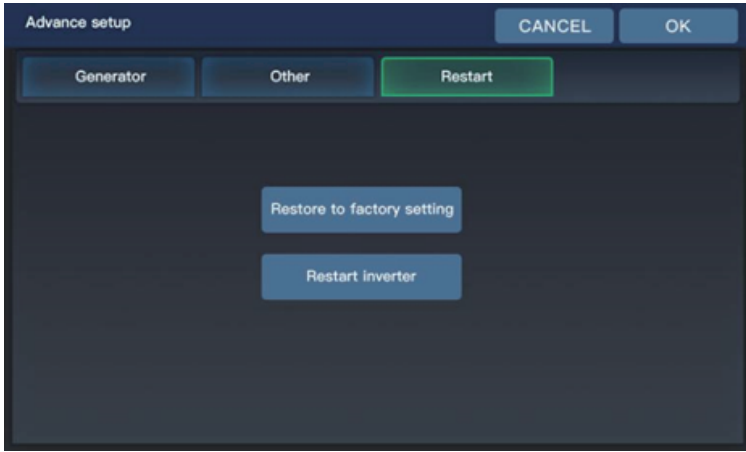

Figure 5-13 Restart

Parameter Meaning	Description
Restore Factory Settings	Reset all inverter settings
Reboot Inverter	Restart the inverter

5.3 Time-slot Charging / Discharging Function

The HI5-1P6K-LV is equipped with a time-slot charging and discharging function, which allows users to set different charging and discharging periods according to the local peak and valley tariffs, so that the utility power and PV energy can be used rationally.

When mains electricity is expensive, the battery inverter is used to carry the load; when the mains electricity is cheap, the mains electricity is used to carry the load and charge, which can help customers to save electricity costs to the greatest extent.

The user can turn on/off the time-slot charging/discharging function in setup menu parameter 46 and 53, and set charging and discharging slot in parameter. Below are examples for users to understand the function.

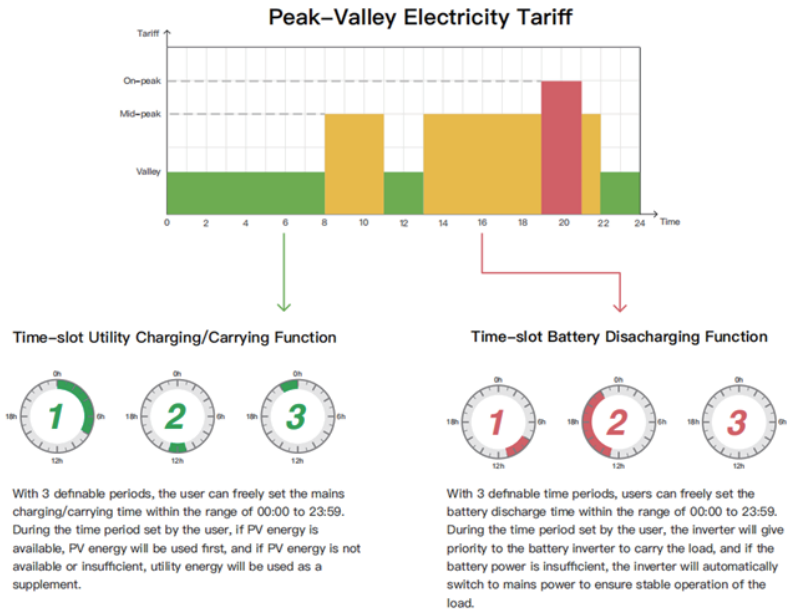

Figure 5-14 Peak-Valley Electricity Tariff

5.4 Battery Parameter

- Lead-acid Battery

Battery Type	Sealed Lead Acid Battery (SLD)	Gel Lead Acid Battery (GEL)	Flooded Lead Acid Battery (FLD)	User-defined (USE)	Adjustable
Overvoltage Disconnection Voltage [V]	60	60	60	60	
Battery Fully Charged Recovery Point [V]	52	52	52	52	
Boost Charge Voltage [V]		/		40 - 60	
Undervoltage Alarm Voltage ([01] Fault) [V]	44	44	44	40 - 60	
Undervoltage Alarm Voltage Recovery Point ([01] fault)		Undervoltage alarm voltage + 0.8 V			
Low Voltage Disconnection Voltage ([04] fault) [V]	42	42	42	40 - 60	
Low Voltage Disconnection Voltage Recovery Point ([04] Fault) (Setup Item [35]) [V]	52	52	52	52	
Discharge Limit Voltage [V]		/		40 - 60	
Over-discharge Delay Time [s]	5	5	5	1 - 30	
Boost Charge Duration [min]		/		10 - 600	

- Li-ion Battery

Battery Type	Ternary (N13)	Ternary (N14)	LFP (L16)	LFP (L15)	LFP (L14)	Adjustable
Overvoltage Disconnection Voltage [V]	60	60	60	60	60	
Battery Fully Charged Recovery Point [V]	50.4	54.8	53.6	50.4	47.6	
Equalizing Charge Voltage			/			
Boost Charge Voltage [V]	53.2	57.6	56.8	53.2	49.2	
Undervoltage Alarm Voltage ([01] Fault) [V]	43.6	46.8	49.6	46.4	43.2	
Undervoltage Alarm Voltage Recovery Point ([01] fault)		Undervoltage alarm voltage + 0.8 V				
Low Voltage Disconnection Voltage ([04] fault) [V]	38.8	42	48.8	45.6	42	
Low Voltage Disconnection Voltage Recovery Point ([04] Fault) (Setup Item [35]) [V]	46	49.6	52.8	49.6	46	
Discharge Limit Voltage [V]	36.4	39.2	46.4	43.6	40.8	
Over-discharge Delay Time [s]			30			
Boost Charge Duration [min]			120			

6.1 Overview

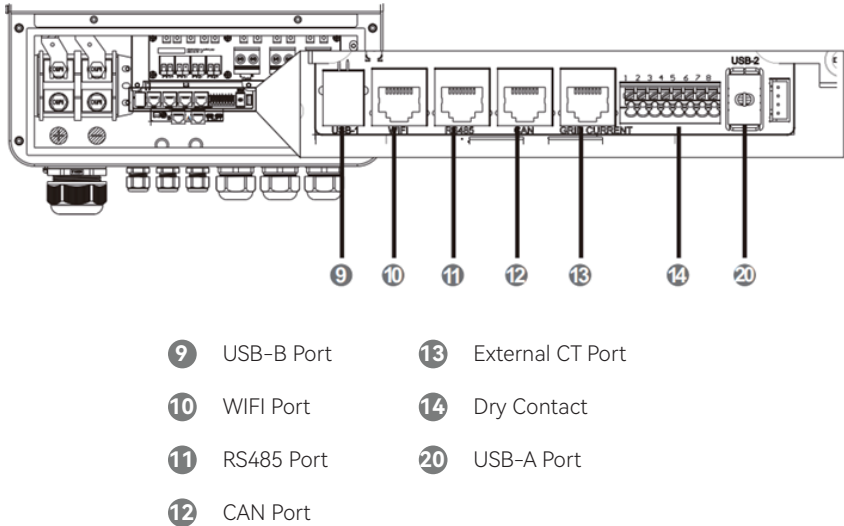

Figure 6-1 Communication Connection Overview

6.2 USB-B Port

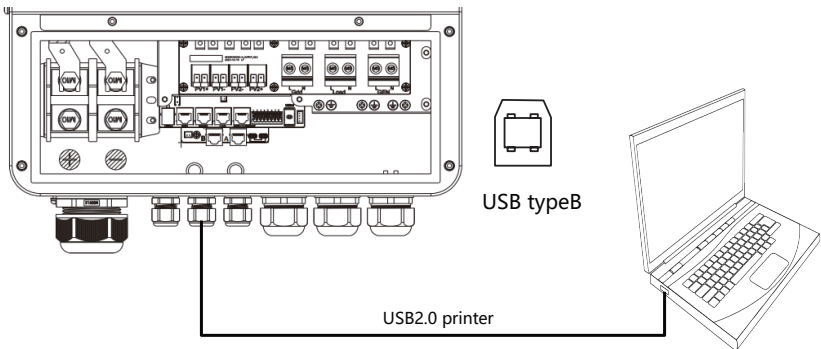

Figure 6-2 USB-B Port

The user can read and modify device parameters through this port by using the host software. Please contact us for the host software installation package if you require one.

6.3 WIFI Port

The WIFI port is used to connect to the Wi-Fi / GPRS logger module, which allows users to view the operating status and parameters of the inverter via mobile phone APP.

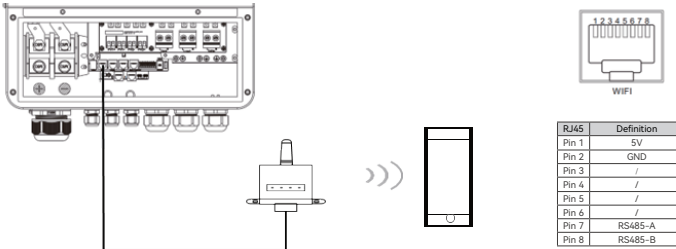

Figure 6-3 WIFI Port

6.4 CAN Port

The CAN port is used to connect to the BMS of Li-ion battery.

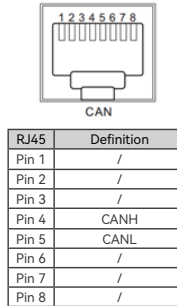
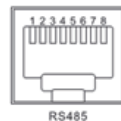

Figure 6-4 CAN Port

6.5 RS485 Port

The RS485 port is used to connect to the BMS of Li-ion battery. Pin4 and Pin5 are for CAN.



If you need to use the inverter to communicate with the lithium battery BMS, please contact us for the communication protocol or upgrade the inverter to the appropriate software programme.

RJ45	Definition
Pin 1	RS485-B
Pin 2	RS485-A
Pin 3	GND
Pin 4	CANH
Pin 5	CANL
Pin 6	GND
Pin 7	RS485-A
Pin 8	RS485-B

Figure 6-5 RS485 Port

6.6 USB-A Port

It is used to updated the LCD screen firmware.

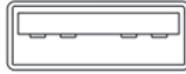

Figure 6-6 USB-A Port

6.7 External CT Port

For external CT model connection.

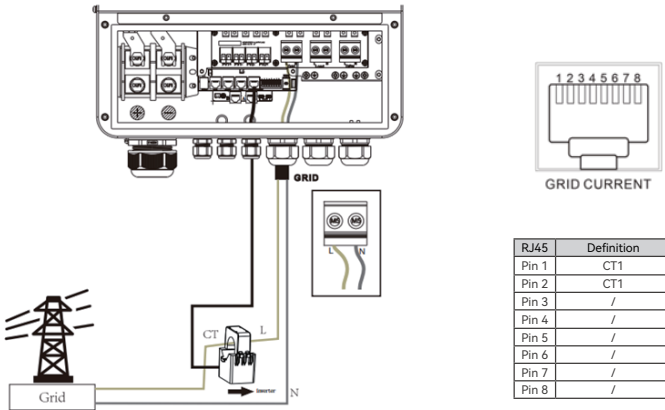

Figure 6-7 External CT Port

- 1 Split Core Current Transformer (CT) dimension: (mm)
- 2 Secondary output cable length is 4 m.
- 3 The CT direction is "to inverter"

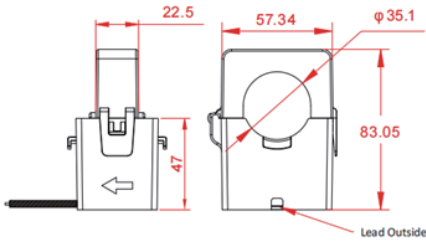

Figure 6-8 CT



6.8 Dry Contact

- 1 RSD power supply
- 2 Temperature sampling (reserved)
- 3 Generator remote start / stop

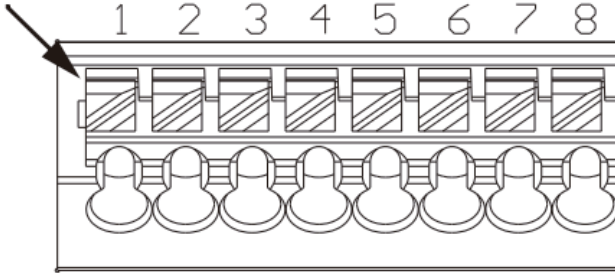

Figure 6-1 Dry Contact

Function	Description
RSD power supply	PIN 1 is GND, PIN 2 is RSD 12V+
Temperature sampling (reserved)	Pin 1 & Pin 5 can be used for battery temperature sampling compensation.
Generator remote start / stop	6-7: NC 6-8: NO Remote generator shutdown: Pins 6 to 7 are normally closed, and pins 7 to 8 are normally open. (Pin 6/7/8 output 125Vac/1A,230Vac/1A,30Vdc/1A)

i NOTICE

If you need to use the remote start / stop function of the generator with dry contact, ensure that the generator has ATS and supports remote start / stop.

7.1 Fault Code

Fault Code	Fault Name	Whether it affects the output or not	Description
[01]	BatVoltLow	No	Battery undervoltage alarm.
[02]	BatOverCurrSw	Yes	Battery discharge average current overcurrent (software protection).
[03]	BatOpen	Yes	Battery not-connected alarm.
[04]	BatLowEod	Yes	Battery undervoltage stop discharge alarm.
[05]	BatOverCurrHw	Yes	Battery overcurrent (hardware protection).
[06]	BatOverVolt	Yes	Charging overvoltage protection.
[07]	BusOverVoltHw	Yes	Bus overvoltage (hardware protection).
[08]	BusOverVoltSw	Yes	Bus overvoltage (software protection).
[09]	PvVoltHigh	No	PV overvoltage protection.
[10]	PvOCSw	No	Boost overcurrent (software protection).
[11]	PvOCHw	No	Boost overcurrent (hardware protection).
[13]	OverloadBypass	Yes	Bypass overload protection.
[14]	OverloadInverter	Yes	Inverter overload protection.
[15]	AcOverCurrHw	Yes	Inverter overcurrent (hardware protection).
[17]	InvShort	Yes	Inverter short-circuit protection.
[19]	OverTemperMppt	No	Buck heat sink over temperature protection.
[20]	OverTemperInv	Yes	Inverter AC output with load or AC charging radiator over-temperature protection.
[21]	FanFail	Yes	Fan blockage or failure fault.

Fault Code	Fault Name	Whether it affects the output or not	Description
[22]	EEPROM	Yes	Memory failure.
[23]	ModelNumErr	Yes	Model setting error.
[26]	RlyShort	Yes	Inverted AC Output Backfills to Bypass AC Input.
[29]	BusVoltLow	Yes	Internal battery boost circuit failure.
[30]	BatCapacityLow1	No	Alarm given when battery capacity rate is lower than 10% (setting BMS to enable validity).
[31]	BatCapacityLow2	No	Alarm given when battery capacity rate is lower than 5% (setting BMS to enable validity).
[32]	BatCapacityLowStop	Yes	Inverter stops when battery capacity is low (setting BMS to enable validity).
[34]	CanCommFault	Yes	CAN communication fault in parallel operation.
[35]	ParaAddrErr	Yes	Parallel ID (communication address) setting error.
[37]	ParaShareCurrErr	Yes	Parallel current sharing fault
[38]	ParaBattVoltDiff	Yes	Large battery voltage difference in parallel mode.
[39]	ParaAcSrcDiff	Yes	Inconsistent AC input source in parallel mode.
[40]	ParaHwSynErr	Yes	Hardware synchronization signal error in parallel mode.
[41]	InvDcVoltErr	Yes	Inverter DC voltage error.
[42]	SysFwVersionDiff	Yes	Inconsistent system firmware version in parallel mode.
[43]	ParaLineContErr	Yes	Parallel line connection error in parallel mode.
[44]	Serial number error	Yes	No serial number set at factory.
[45]	Error setting of split-phase mode	Yes	Item "Parallel" setting error.

Fault Code	Fault Name	Whether it affects the output or not	Description
[49]	Grid over voltage	Yes	
[50]	Grid under voltage	Yes	
[51]	Grid over frequency	Yes	
[52]	Grid under frequency	Yes	Selects the local corresponding grid standard.
[53]	Grid loss	Yes	
[54]	Grid DC current over	Yes	
[55]	Grid standard un init	Yes	
[56]	Low insulation resistance fault	Yes	
[57]	Leakage current overload fault	Yes	System leakage current exceeds limit.
[58]	BMS communication error	No	Check whether the communication line is connected correctly and whether [33] is set to the corresponding lithium battery communication protocol.
[60]	BMS battery low temperature alarm	No	BMS alarm battery low temperature.
[61]	BMS battery over temperature alarm	No	BMS alarm battery over temperature.
[62]	BMS battery over current alarm	No	BMS alarm battery over current.
[63]	BMS battery undervoltage alarm	No	BMS alarm low battery.

7.2 Troubleshooting

Fault Code	Meaning	Remedy
/	No screen display	Check whether the battery air circuit-breaker or PV air circuit-breaker is turned on. Check if the switch is "ON". Press any button on the screen to exit the screen sleep mode.
06	Battery overvoltage protection	Check that the battery voltage does not exceed the protection value. If it does, discharge the battery until the voltage falls below the battery over-voltage recovery point.
01 04	Battery undervoltage protection	Charge the battery until it returns to the low voltage disconnection recovery voltage.
21	Fan failure	Check if the fan is not turning or blocked by foreign object.
19 20	Heat sink over temperature protection	When the temperature of the device is cooled below the recovery temperature, normal charge and discharge control is resumed.
13 14	Bypass overload protection, inverter overload protection	<ol style="list-style-type: none"> 1 Reduce the use of power equipment; 2 Restart the unit to resume load output.
17	Inverter short-circuit protection	<ol style="list-style-type: none"> 1 Check the load connection carefully and clear the short-circuit fault points; 2 Re-power up to resume load output.
09	PV overvoltage	Use a multimeter to check if the PV input voltage exceeds the maximum allowable input voltage rated.
03	Battery disconnected alarm	Check if the battery is not connected or if the battery circuit breaker is not closed.
40 43	Parallel connection fault	Check if the parallel line is not connected well, such as loose or wrong connection.
35	Parallel ID setting error	Check whether the setting of parallel ID number is repeated.
37	Parallel current sharing fault	Check if the parallel current sharing line is not connected well, such as loose or wrong connection.
39	Inconsistent AC input source in parallel mode	Check whether the parallel AC inputs are from the same input interface.
42	Inconsistent system firmware version in parallel mode	Check whether the software version of each inverter is consistent.

Fault Code	Meaning	Remedy
44	Serial number error	Incorrect device serial number setting.
45	Parallel mode error	There is a device in the parallel system with the wrong parallel mode setting.
49	High grid voltage	Check that the grid voltage is within the normal range, if the grid voltage is abnormal, wait until the grid voltage is restored.
50	Low grid voltage	Check that the grid voltage is within the normal range, if the grid voltage is abnormal, wait until the grid voltage is restored.
51	High grid frequency	Check that the grid frequency is within the normal range, if the grid frequency is abnormal, wait until the grid frequency is restored.
52	Low grid frequency	Check that the grid frequency is within the normal range, if the grid frequency is abnormal, wait until the grid frequency is restored.
53	Grid unconnected	Check if the grid is correctly connected, e.g. if the switch is closed and if the grid is disconnected.
54	Grid-connected current with DC component over	Power down and restart the device, if it continues to report faults, contact the manufacturer after sales.
56	Low insulation resistance fault	Check that the system is well grounded and that the PV modules and cables are not worn.
57	Leakage current overload fault	Check that the system is well grounded and that the loads are not operating abnormally.

NOTICE

If you encounter product faults that cannot be solved by the methods in the above table, please contact our after-sales service department for technical support and do not disassemble the equipment by yourself.

8.1 Protection Function

No.	Protection Functions	Description
1	PV input current / power limiting protection	When the charging current or power of the PV array configured exceeds, the PV input rated value, the inverter will limit the input power and charge at the rated.
2	PV input over-voltage	If the PV voltage exceeds the maximum value allowed by the hardware, the machine reports a fault and stops PV boosting to output a sinusoidal AC waveform.
3	Anti-reverse charge protection at night	At night, the battery will be prevented from discharging to the PV module because the battery voltage is greater than the PV module voltage.
4	AC input over-voltage protection	When the mains voltage of per phase exceeds 280Vac, the mains charging will be stopped and will switch to inverter output.
5	AC input under-voltage protection	When the mains voltage of per phase falls below 170 Vac, the mains charging will be stopped and will switch to inverter output.
6	Battery over-voltage protection	When the battery voltage reaches the over-voltage disconnection voltage point, it will automatically stop the PV and mains charging of the battery to prevent over-charging and damage to the battery.
7	Battery under-voltage protection	When the battery voltage reaches the low-voltage disconnection voltage point, it will automatically stop discharging the battery to prevent the battery from being over-discharged and damaged.
8	Battery over-current protection	When the battery current exceeds the range allowed by hardware, the machine will turn off output and stop discharging the battery.
9	AC output short-circuit protection	When a short-circuit fault occurs at the load, the AC output voltage will be switched off immediately and output again after 1 min. If the output load is still short-circuited after 3 attempts, short-circuit fault of the load must be eliminated first and then manually re-powered in order to restore the normal output.
10	Heat sink over-temperature protection	When the internal temperature of the inverter is too high, the inverter will stop charging and discharging; when the temperature returns to normal, the inverter will resume charging and discharging.

No.	Protection Functions	Description
11	Inverter over-load protection	Three phase overload logic: After triggering the overload protection, the inverter will resume output after 3 minutes, 5 consecutive overloads will shut down the output until the inverter is restarted. (102%<load<110%):alarm,output shut down after 5 minutes. (110%<load<125%):alarm, output shut down after 20s. (125%<load<200%):alarm, output shut down after 10s. Single phase overload logic: 1.5*(102%<load<110%) :alarm, output shut down after 5 minutes. 1.5*(load>110%): alarm, output shut down after 10s.
12	AC output reverse	Prevents backfeeding of battery inverter AC to bypass AC inputs.
13	Bypass over-current protection	Built-in AC input overcurrent protection circuit breaker.
14	Bypass phase inconsistency protection	When the phase of the two bypass inputs is different from the phase of the inverter phase split, the machine will prohibit cutting into the bypass to prevent the load from dropping out or short-circuiting when cutting into the bypass.
15	Charging short-circuit protection	When the external battery port is short-circuited in the PV or AC charging state, the inverter will protect and stop the output current.
16	Parallel connection error protection	In parallel operation, the equipment will be protected when the parallel line is lost.
17	Parallel battery voltage difference protection	In parallel operation, the equipment will be protected when the battery connection is inconsistent and the battery voltage is greatly different from that detected by the host.
18	Parallel AC voltage difference protection	In parallel operation, the equipment will be protected when the AC IN input connection is inconsistent.
19	Synchronization signal fault protection	The equipment will be protected when there is a fault in the guidance signal between parallel buses, causing inconsistent behavior of each inverter.

8.2 Maintenance

To maintain optimum long-lasting working performance, it is recommended that the following items be checked twice a year.

- 1 Ensure that the airflow around the inverter is not blocked and remove any dirt or debris from the radiator.
- 2 Check that all exposed conductors are not damaged by sunlight, friction with other surrounding objects, dry rot, insect or rodent damage, etc. The conductors need to be repaired or replaced if necessary.
- 3 Verify that the indications and displays are consistent with the operation of the equipment, note any faults or incorrect displays and take corrective action if necessary.
- 4 Check all terminals for signs of corrosion, insulation damage, high temperatures or burning / discolouration and tighten terminal screws.
- 5 Check for dirt, nesting insects and corrosion, clean as required. Clean the insect screen regularly.
- 6 If the lightning arrester has failed, replace the failed arrester in time to prevent lightning damage to the inverter or other equipment of the user.



DANGER!

- Make sure that the inverter is disconnected from all power sources and that the capacitors are fully discharged before carrying out any checks or operations to avoid the risk of electric shock.

The Company shall not be liable for damage caused by:

- 1 Damage caused by improper use or use in a wrong location.
- 2 Photovoltaic modules with an open circuit voltage exceeding the maximum permissible voltage.
- 3 Damage caused by the operating temperature exceeding the restricted operating temperature range
- 4 Dismantling and repair of the inverter by unauthorised persons.
- 5 Damage caused by force majeure: damage during transport or handling of the inverter.

- Inverter Output

Model	HI5-1P10K-LV	Settable
Rated Output Power [W]	10000	
Max. Peak Power [VA]	20000	
Rated Output Voltage [Vac]	230 (Single phase) (200 / 208 / 220 / 240 settable)	Y
Output Voltage Error	± 5%	
Load Capacity of Motors	6 HP	
Rated AC Frequency [Hz]	50 / 60 ± 0.3	Y
Waveform	Pure Sine Wave	
Switch Time [ms]	10 (typical)	
Overload	After triggering the overload protection, the inverter will resume output after 3 minutes, 5 consecutive overloads will switch off the output until the inverter is restarted. (102% < load < 125%): alarm and output shutdown after 5 min; (125% < load < 150%): alarm and output shutdown after 10 s. Load > 150% : alarm reported and output switched off after 5 s.	

- AC Output (On Grid)

Model	HI5-1P10K-LV	Settable
Rated Output Power [W]	10000	
Max. Peak Power [VA]	10000	
Power Factor	0.8 leading to 0.8 lagging	
Rated Voltage [Vac]	220 / 230	
Rated AC Frequency [Hz]	50 / 60	
Rated AC Output Phase Current [Aac]	43.5	
THD	< 3%	

- Battery

Model	HI5-1P10K-LV	Settable
Battery Type	Li-ion / Lead-Acid / User Defined	Y
Rated Battery Voltage [Vdc]	48 (minimum start-up voltage 44)	
Voltage Range [Vdc]	40 - 60	
Max. Generator Charging Current [Adc]	60	Y
Max. Grid Charging Current [Adc]	120	Y
Max. Hybrid Charging Current [Adc]	200	Y

- PV Input

Model	HI5-1P10K-LV	Settable
Num. of MPP Trackers	2	
Max. PV Array Power [W]	5500 / 5500	
Max. Input Current [Adc]	22 / 22	
Max. PV Isc [Adc]	37 / 37	
Max. Voltage of Open Circuit [Vdc]	500	
MPPT Voltage Range [Vdc]	125 - 425	

- Grid / Generator Input

Model	HI5-1P10K-LV	Settable
Input Voltage Range [V]	90 ~ 280	
Frequency Range [Hz]	50 / 60	
Max.AC Bypass Current [Aac]	63	

- Efficiency

Model	HI5-1P10K-LV	Settable
MPPT Tracking Efficiency	99.9%	
Max. Battery Inverter Efficiency	97.5%	
European Efficiency	97%	

- Protection

Model	HI5-1P10K-LV	Settable
PV Input Lightning Protection	Yes	
Anti-islanding Protection	Yes	
PV String Input Reverse Polarity Protection	Yes	
Insulation Resistor Detection	Yes	
Residual Current Monitoring Unit	Yes	
Output Over Current Protection	Yes	
Output Shorted Protection	Yes	
Surge Protection	DC Type II / AC Type II	
Over Voltage Category	DC Type II / AC Type III	

- Certified Specifications

Model	HI5-1P10K-LV	Settable
On-Grid Standard	EN50549, G99, NRS-097	
Safety	IEC62109-1, IEC62109-2	
EMC	EN61000-6-1, EN61000-6-3, FCC 15 class B	
RoHS	Yes	

- Basic Data

Model	HI5-3P10K-LV	Settable
Parallel Capacity	6	
Operating Temperature Range [°C]	-25 ~ 60, > 45 derated	
Humidity range	0 - 100%	
Warranty [Years]	5	
Noise [dB]	< 60	
Protection Degree	IP65	
Cooling Method	Heat Sink + Intelligent Fan Cooling	
Self-consumption [W]	< 100	
Dimensions [mm]	670 × 440 × 240	
Weight [kg]	39	
Communication port	RS485 / CAN / USB / Dry Contact	Y
External Modules (Optional)	Wi-Fi / GPRS	Y



YINERGY DIGITAL POWER TECHNOLOGY CO., LTD.

Add: No.161 Yuancheng Road, Qiantang District,
Hangzhou, Zhejiang, China
Tel: +86 (0) 571 5626 0011
Email: support@yinergy-solar.com

Copyright © 2024 Yinergy Digital Power Technology Co., Ltd. All Rights Reserved.